

FASTENING CATALOGUE

INDEX

About Zippers	2
Metal Zippers	4
Coil Zippers	16
VISLON® Zippers	32
Precautions on Zipper Use	43
Precaution for Zipper Sewing	60
Zipper Problems and Solutions (Q & A)	66
Snap Fastener and Button Products	68
Snap Fastener and Button Attaching Machine	76
Snap Fastener and Button Products Attachment and Inspection Guides	77
Ball Chain	83
JOYLON®	84
Cosmolon®	85
Plastic Hardware	87
Beware of Counterfeit YKK Zippers	93
YKK Worldwide Network	94

Please note that the photo images may not look exactly the same as the actual items due to various factors, including display and color capability of printing.

Page numbers marked with ⚠ are topics related to the specific product.

Structure of Zippers

Closed-End Zipper

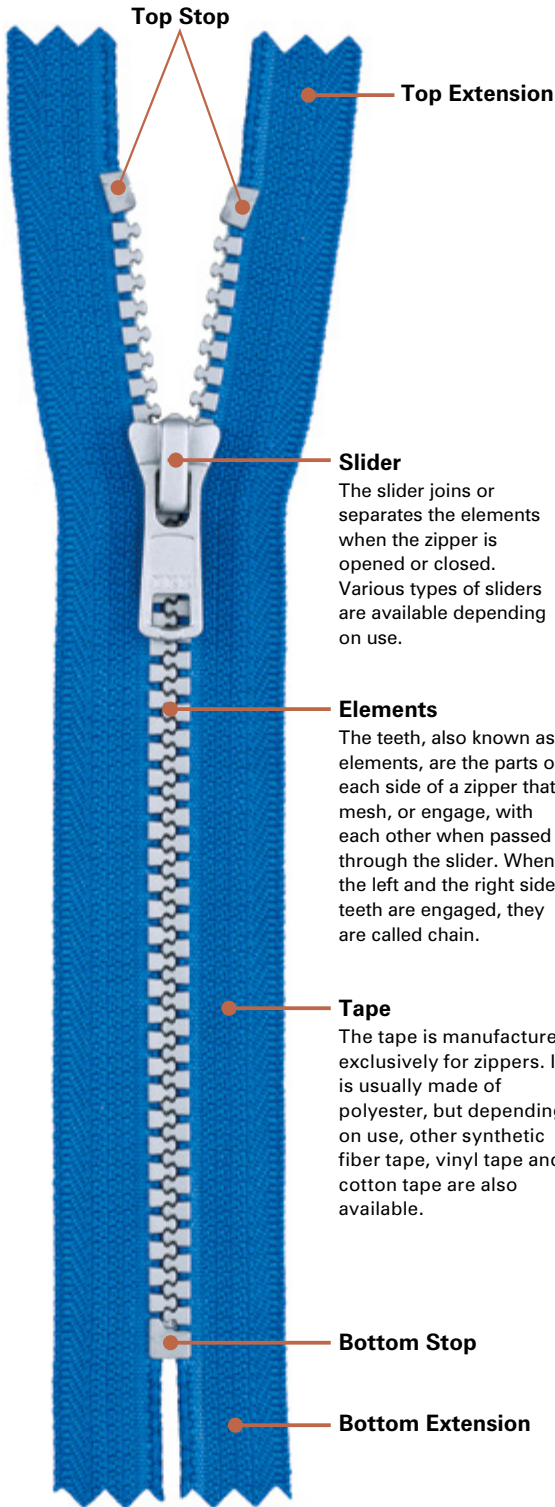



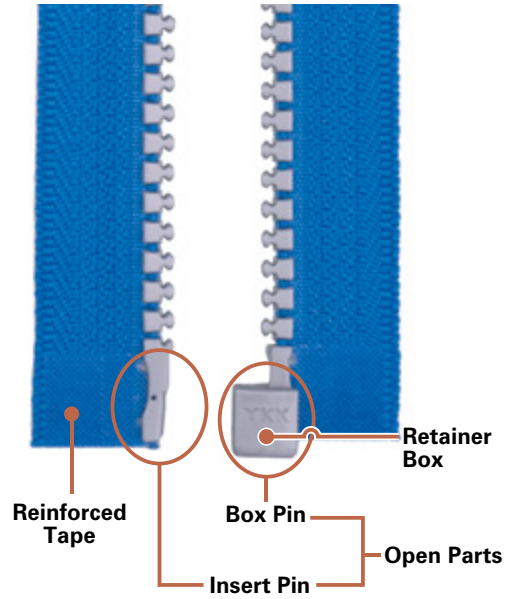

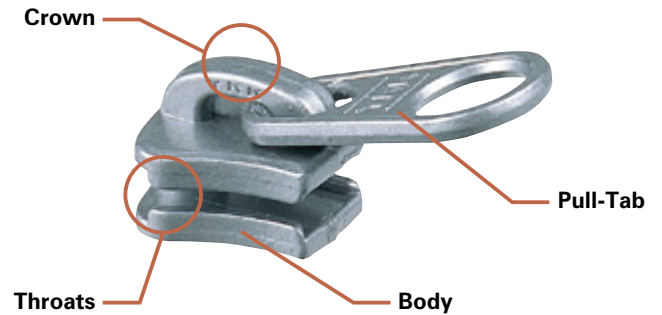

Open-End Zipper



Slider



Basic Sliders

Non-Lock Slider	Automatic Lock Slider	Semi-Automatic Lock Slider
 <p>(DF)</p> <p>This slider has no locking mechanism.</p>	 <p>(DA)</p> <p>The locking mechanism automatically functions when the pull-tab is released.</p>	 <p>(DS)</p> <p>The locking mechanism functions when the pull-tab is snapped down.</p>
Jeans Slider	Reversible Slider	Double-Pulled Sliders
 <p>(GS)</p> <p>Semi-automatic lock slider for Jeans.</p>	 <p>(DU)</p> <p>The pull-tab moves along the rotating rail, enabling the operation from both sides. (Automatic Lock type)</p>	 <p>(DW)</p> <p>The pull-tab is attached on both sides of the sliders, enabling the operation from both sides.</p>

Function of Zippers

Closed-End

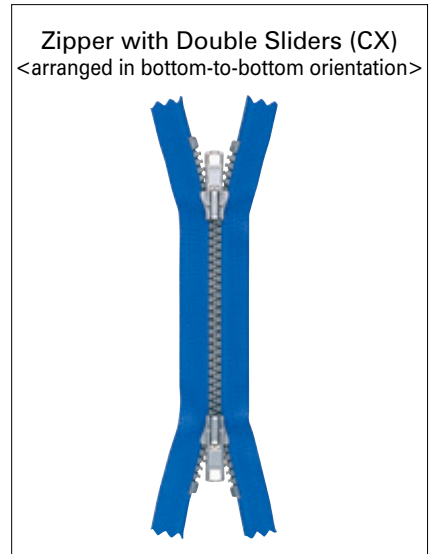
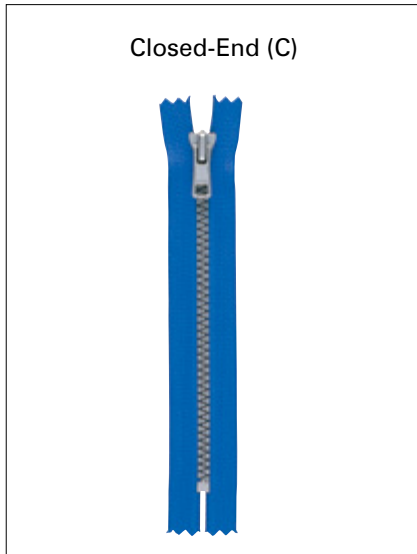

Open-End

Open-End
[Separator] (O)

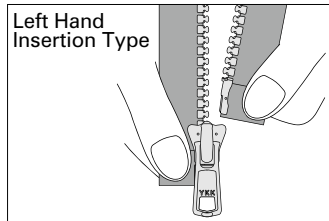
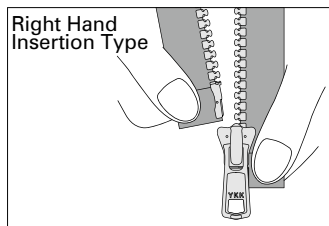

Two-Way Open

Two-Way Open (M)

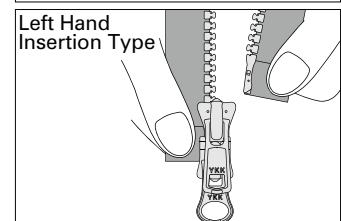
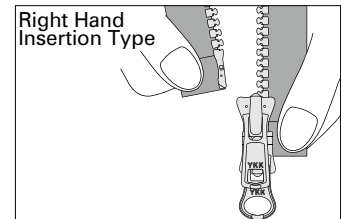
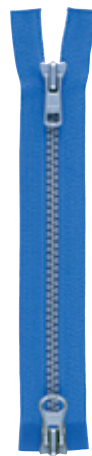

Zipper Code

Exp:

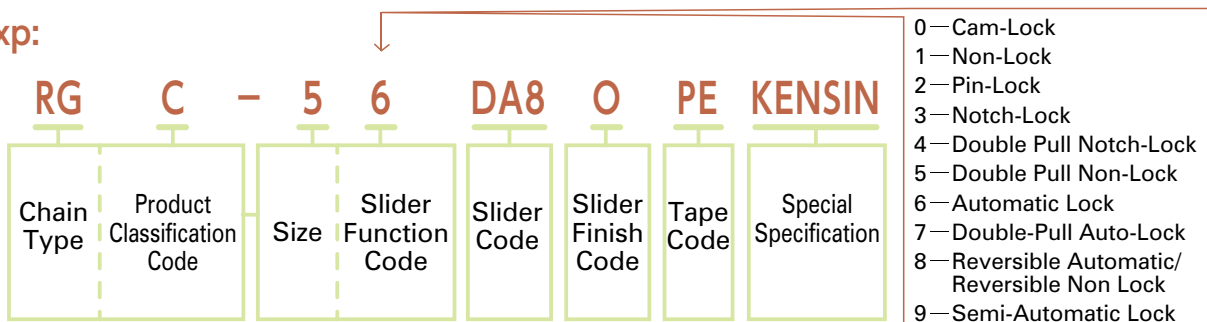

Various Sizes of Metal Zippers

Standard



No.3

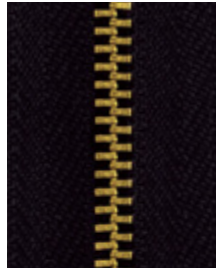

No.4

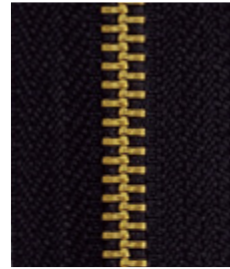

No.5



No.7



No.8

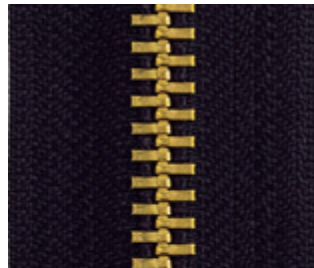

No.10

YZiP®



No.3



No.4



No.5



No.8
(YAN)

Metal
Zippers

Various Sizes of Metal Zippers

EXCELLA®

Single Type



No.2



No.3



No.5



No.8

Double Type (Double Sliders can be used)



No.3



No.5

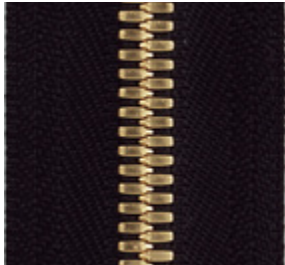

No.8

EXCELLA® Light



No.3

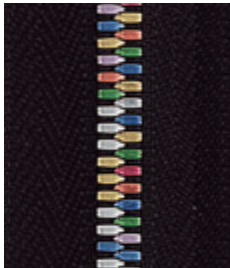

No.5

Symmetric Zipper



No.5

PROSEAL®

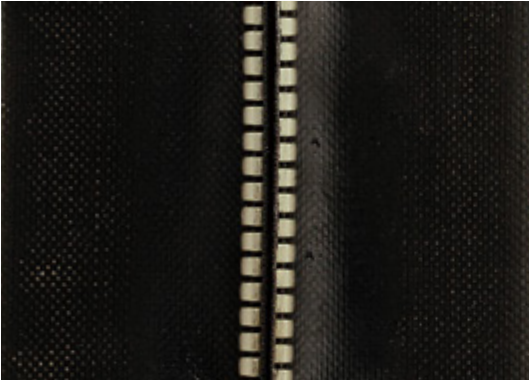

No.8

Metal Zippers

Metal Zipper (Standard)

Metal Zippers

Metal Zipper (Standard)



RGC-56 DA8 O PE

■ Metal zippers are the oldest type of zipper, the elements of which are comprised of metals such as golden brass, aluminum and nickel.

Size	Closed-End	Open-End	Two-Way Open
2	○	○	—
3	○	○	—
4	○	○	—
5	○	○	○
7	○	○	—
8	○	○	○
10	○	○	○

Element Color Variation

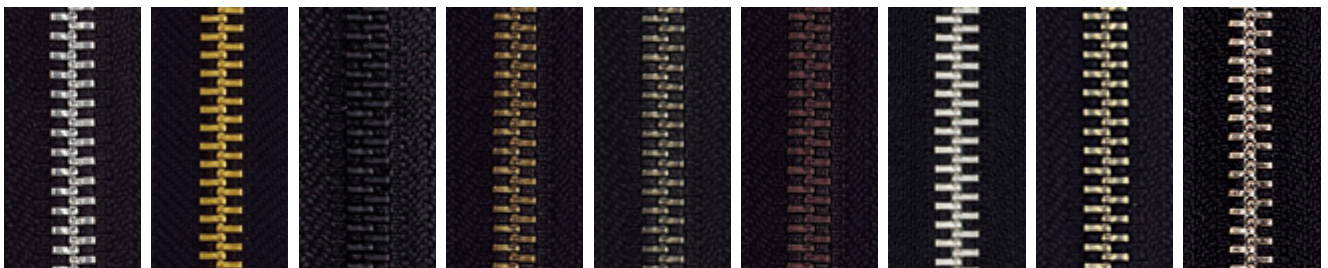

Aluminum Golden Brass Black Oxidized Antique Gold Antique Silver Antique Copper Dull-Silver Nickel-Silver Anti-Nickel-Silver

Standard Metal Zippers Type

Size	Aluminum	Golden Brass	Black Oxidized	Antique Gold	Antique Silver	Antique Copper	Dull-Silver	Nickel-Silver	Anti-Nickel-Silver
3	MA	MG	MGK	MGKB	MGTH	MGTX		MN	MMN
4	MA	MG	MGK	MGKB	MGTH	—		MN	—
5	RA	RG	RGK	RGKB	RGTH	RGTX		RN	RMN
7	MA	MG	MGK	MGKB	MGTH	MGTX		MN	—
8	MA	※	※	※	※	※	※	—	—
10	MA	MG	MGK	MGKB	MGTH	MGTX	MGDS	MN	—

Metal Zipper with Double Sliders Type

Size	Aluminum	Golden Brass	Black Oxidized	Antique Gold	Antique Silver	Dull-Silver	Nickel-Silver	Anti-Nickel-Silver
5	RAM	RGM	RGMK	RGMKB	RGMTH	—	RNM	RMNM
7	MAM	MGM	MGMK	MGMKB	MGMTH	—	MNM	—
8	MAM	MGM	MGMK	MGMKB	MGMTH	MGMS	—	MMNM
10	MAM	MGM	MGMK	MGMKB	MGMTH	MGMS	—	—

※With regards to size 8, please use the double slider type elements even for products with just one slider. (excluding aluminum).

⚠ P48~P50

Jeans / Trousers Zipper YZiP®



YGRC-39 GSN8 J CP

- This is a strong zipper with thicker elements than those of standard metal zipper.
- There are two types of elements for this zipper: golden brass and nickel.
- This zipper withstands washing processes.
- There are two types of tapes: polyester tape & cotton polyester tape.

Size	Closed-End	Open-End	Two-Way Open
3	○	○	○
4	○	○	-
5	○	○	-

Element Color Variation

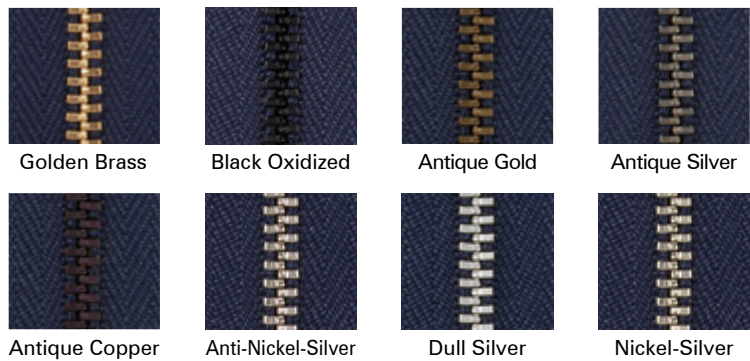

Size	Golden Brass	Black Oxidized	Antique Gold	Antique Silver	Antique Copper	Anti-Nickel-Silver	Dull Silver	Nickel-Silver
3	YGR	YGRK	YGRKB	YGRTH	YGRTX	YMRN	YGRDS	YNR
4	YG	-	YGKB	YGTH	-	-	-	-
5	YG	YGK	YGKB	YGTH	-	-	-	YN

※Deterioration may occur depending on the washing process. Please run a quality confirmation test beforehand.

※Tape code: CP (Cotton · Polyester) is available in golden brass, nickel, antique gold and antique silver elements types.

YZiP® Aluminum



YANOR-56 DA8 C5 P TS-2TL3

- This is a strong zipper with thicker elements than those of standard metal zipper.

Size	Chain Type	Closed-End	Open-End	Two-Way Open
3	YAN	○	○	-
4		○	○	-
5		○	○	-
8		○	○	-

※As the elements of YZiP® Aluminum are made of aluminum alloy, this zipper does not withstand the washing process.

Metal Zippers

EVERBRIGHT®



- Gloss-polished zippers, are smooth to the touch, glossy and highly corrosion resistance compare to the standard metal zipper.
- YZiP® element type is also available.

Size	Chain Type				Function of Zipper		
	Golden Brass	Nickel-Silver	Anti-Nickel-Silver	Nickel-Light-Gold	Closed-End	Open-End	Two-Way Open
3	MGP	MNP	MGPS	MOP	○	○	—
4	MGP	MNP	—	—	○	○	—
5	RGP (RGMP)	RNP (RNMP)	RGPS (RGMPS)	ROP (ROMP)	○	○	○
7	MGP	MNP (MNMP)	—	—	○	○	—
8	MGMP	—	—	MOMP	○	○	—
10	MGP	MNP	—	—	○	○	—

RGPC-56 DA8 KQ PE BS-SGBH TS-SGTD

Surface Finish Variation



Golden Brass

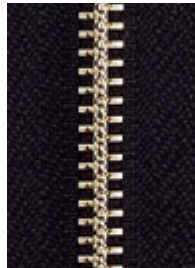

Nickel-Silver

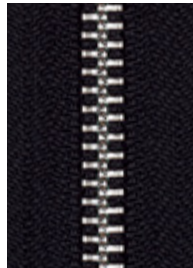

Anti-Nickel-Silver

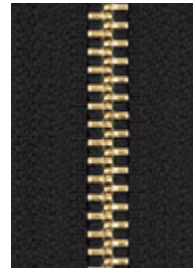

Nickel-Light-Gold

- ※ () under Chain type is for Two-way open or double sliders.
- ※ 8MGMP can be used for both single slider zipper and double slider zipper.
- ※ YZiP® type is available in size "3" and "5" (close and open type only).

Shiny Metal Zipper



RGVGOR-56 DA8P0015 VL1 PE14 EB KENSIN N-ANTI T-TL

- Shiny appearance in various colors.
- YZip® element type is also available.

Shiny Gunmetal (PVG)

Size	Chain	Closed-End	Open-End	Two-Way Open
5	RGPVG	○	○	–

Shiny Lemon Gold

Size	Chain	Closed-End	Open-End	Two-Way Open
3	MBLP	○	○	–
3	YBLRP	○	–	–
5	RBLP	○	○	–

Shiny Silver

Size	Chain	Closed-End	Open-End	Two-Way Open
3	MGPS1	○	○	–
3	YGRPS1	○	–	–
5	RG(M)PS1	○	○	○
8	MG(M)PS1	○	○	○

Shiny Light Gold

Size	Chain	Closed-End	Open-End	Two-Way Open
3	MGP3	○	○	–
3	YGRP3	○	–	–
5	RG(M)P3	○	○	○
8	MG(M)P3	○	○	○

Shiny Gunmetal (PV1)

Size	Chain	Closed-End	Open-End	Two-Way Open
3	MGPV1	○	○	–
5	RGPV1	○	○	○
8	MG(M)PV1	○	○	○

Shiny Black

Size	Chain	Closed-End	Open-End	Two-Way Open
3	MGLV5	○	○	–
5	RG(M)LV5	○	○	○

Element Color Variation

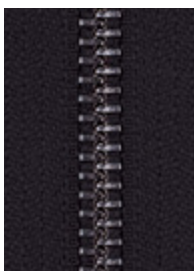

Shiny Gunmetal (PVG)

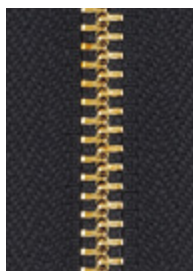

Shiny Lemon Gold

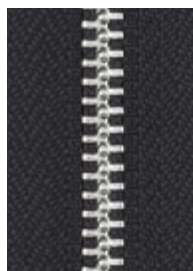

Shiny Silver

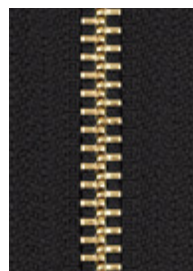

Shiny Light Gold

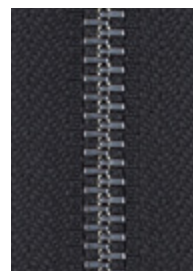

Shiny Gunmetal (PV1)

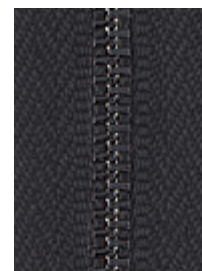

Shiny Black

Metal Zippers

EXCELLA®

Metal Zippers
EXCELLA®



- Individual element of the zipper is polished and plated.
- Items are available in surface colors including silver, gold and antique finish.
- Double sliders can be used.

Size	Type of Element		Function of Zipper		
			Closed-End	Open-End	Two-Way Open
2	Single	SG	○	○	—
3	Single	SGY	○	○	—
	Double	SGW	○	○	○
5	Single	SGY	○	○	—
	Double	SGW	○	○	○
8	Single	SGY	○	○	—
	Double	SGW	○	○	○

Type of Elements

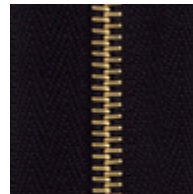

Single Type



Double Type

SGWOGC-56 DA8 OU P14D C-RAKKA

Surface Finish Variation



Golden Brass (OG)



Antique Brass (I)

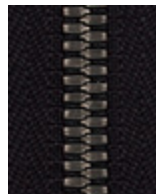

Antique Silver (H1, H3)

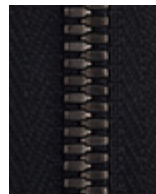

Black Silver (V3)

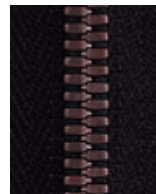

Antique Copper (X)

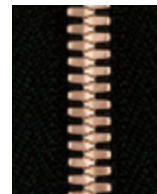

Pink Gold (QP)

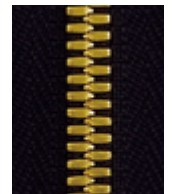

Luxury Gold (Q)



Matte White Bronze (C9)



Silver (White Bronze) (C5)

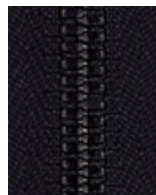

Shiny Black (X7)



Nickel-Silver (P)

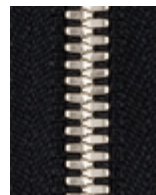

Matte Nickel (PC)

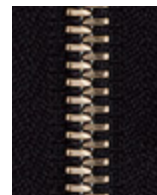

Light Antique Brass (O)

Size	Type of Element	Golden Brass	Antique Brass	Antique Silver	Black Silver	Antique Copper	Pink Gold	Luxury Gold	Matte White Bronze	Silver (White Bronze)	Shiny Black	Nickel-Silver	Matte Nickel	Light Antique Brass
2	Single	SGOG	SGI	SGH1	SGV3	SGX	—	—	—	SGC5	SGX7	—	—	—
3	Single	SGYOG	SGYI	SGYH3	SGYV3	SGYX	SGYQP	SGYQ	SGYC9	SGYC5	SGYX7	SGYP	SGYPC	SGYOI
	Double	SGWOG	SGWI	SGWH3	SGWV3	SGWX	SGWQP	SGWQ	SGWC9	SGWC5	SGWX7	SGWP	SGWPC	SGWOI
5	Single	SGYOG	SGYI	SGYH3	SGYV3	SGYX	SGYQP	SGYQ	SGYC9	SGYC5	SGYX7	SGYP	SGYPC	SGYOI
	Double	SGWOG	SGWI	SGWH3	SGWV3	SGWX	SGWQP	SGWQ	SGWC9	SGWC5	SGWX7	SGWP	SGWPC	SGWOI
8	Single	SGOG	SGI	SGH3	SGV3	SGX	SGQP	SGQ	SGC9	SGC5	SGX7	SGP	SGPC	SGOI
	Double	SGWOG	SGWI	SGWH3	SGWV3	SGWX	SGWQP	SGWQ	SGWC9	SGWC5	SGWX7	SGWP	SGWPC	SGWOI

※ The double type can be used for Two-way open and double sliders.

EXCELLA® Light



- EXCELLA® Light is a type of EXCELLA® zipper that is comprised of aluminum alloy elements.
- This zipper is light weight and has bright color variations and is also available in a multi color chain.

Size	Closed-End	Open-End	Two-Way Open
3	○	○	○
5	○	○	○

Chain Type	Special Feature	Surface Finish Variation
SAW	-	Aluminum
SAWA	EL-SIL2	Antique Silver
	EL-BLK3	Black Silver
	EL-GOL4	Antique Brass
	EL-GOL8	Golden Brass
	EL-RED2	Red
	EL-ORE3	Orange
	EL-VIO3	Purple
	EL-GRN3	Green
	EL-BLK4	Black
	EL-BLU6	Blue
EL-SIL7	Light Antique Silver	
SAWAM	EL-COM2	Mix

SAWAMC-56 DA8 C5 P14D EL-ALMT EL-COM2

Metal Zippers

EXCELLA® Light

Surface Finish Variation



Aluminum

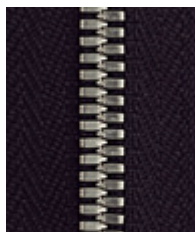

Antique Silver
(EL-SIL2)

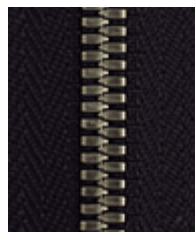

Black Silver
(EL-BLK3)

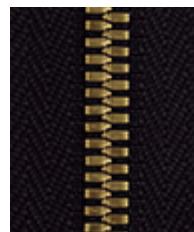

Antique Brass
(EL-GOL4)

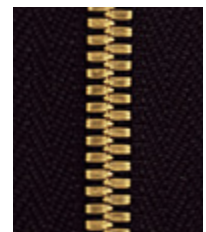

Golden Brass
(EL-GOL8)

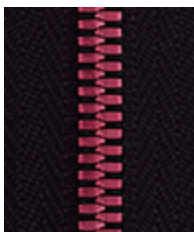

Red
(EL-RED2)

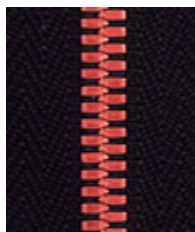

Orange
(EL-ORE3)

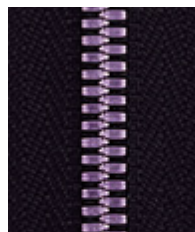

Purple
(EL-VIO3)

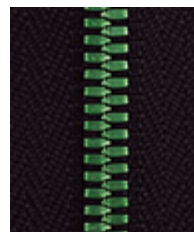

Green
(EL-GRN3)

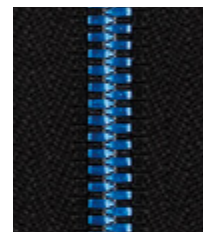

Blue
(EL-BLU6)



Light Antique Silver
(EL-SIL7)

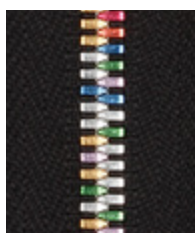

Mix
(EL-COM2)

Metal Zippers

Cotton Touch



■ The zipper has a natural and soft texture like cotton. They are made of polyester and rayon yarn.

Size	Closed-End	Open-End	Two-Way Open
3	<input type="radio"/>	<input type="radio"/>	-
5	<input type="radio"/>	<input type="radio"/>	<input type="radio"/>
7	<input type="radio"/>	<input type="radio"/>	-

Tape Color Variation



RGKBC-56 DA8LH | TRP

※Other colors are also available.

Marble Tape



■ The marbled, soft-touch tape is made of mixed yarn containing polyester and rayon.

■ Various colors are available.

Size	Chain Type	The Color of Elements	Tape	Closed-End	Open-End	Two-Way Open
5	RA	Aluminum	TR16	<input type="radio"/>	<input type="radio"/>	<input type="radio"/>
	RG	Golden Brass		<input type="radio"/>	<input type="radio"/>	<input type="radio"/>
	RGKB(RGMKB)	Antique Gold		<input type="radio"/>	<input type="radio"/>	<input type="radio"/>
	RN(RNM)	Nickel-Silver		<input type="radio"/>	<input type="radio"/>	<input type="radio"/>

Tape Color Variation

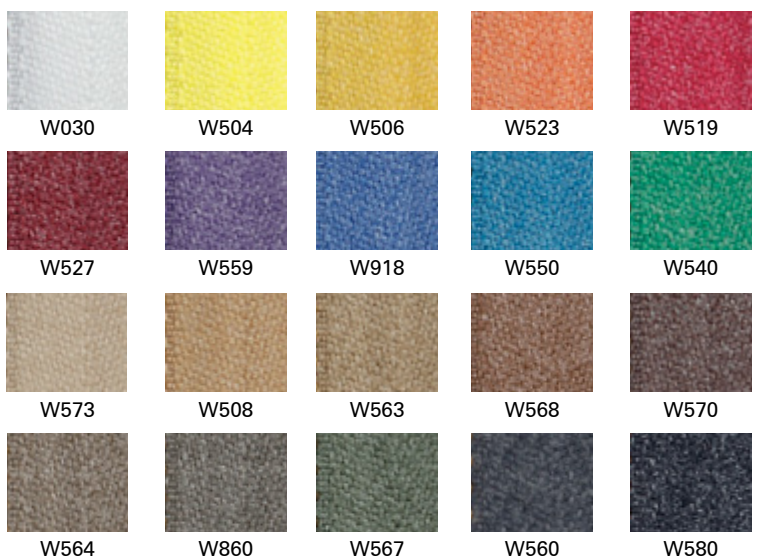

RGC-56 DA8 O TR16

※Chain type "RGMKB" and "RNM" are for zippers with double sliders.
 ※Other colors are also available.

Metal Zippers

Cotton Touch / Marble Tape

PROSEAL® (Water & Airtight Zipper)



TZNC-81 BF SHR2 Z CR M-DUTY PUL-100 W-SEAL

PROSEAL® zipper is the ultimate watertight fastening solution. PROSEAL® technology is based on a strong seal with nickel-silver elements pushed tightly together.

Size	Chain Type	Tape	Closed-End	Open-End	Two-Way Open
4	TZN	PVC	○	—	—
		CR	○	—	—
8	TZN	PVC	○	○	—
		CR	○	○	—
		PU	○	○	—
12	TZN	CR	○	○	—

Material	
Element	Nickel-Silver
Slider	Aluminum Bronze
Tape	Chloroprene Rubber / Polyurethane / PVC

Air tightness test

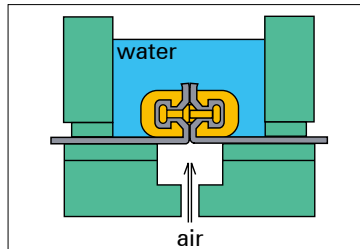

The Structure of PROSEAL®

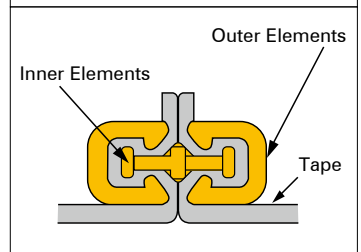

No air bubbles coming up for 15 seconds will indicate that it has passed the test.

*The level of protection is specified from 0.2 to 1.0 bar water pressure, depending on the size, tape and material of the zipper.

▲ P53

Top Open Zipper



MGOR-106 DA O PE TOP-OP2

This item enables you to quickly open the zipper from the top.

Size	Chain Type	Special Specifications	Closed-End	Open-End	Two-Way Open
10	MA	TOP-OP2	—	○	○
	MG				
	MGKB				
	MGK				
	MN				

How to use Top Open Zipper

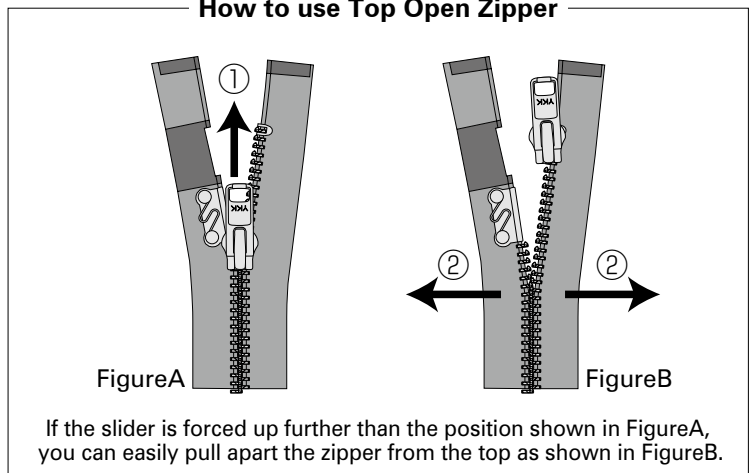

If the slider is forced up further than the position shown in Figure A, you can easily pull apart the zipper from the top as shown in Figure B.

※This zipper is originally designed for quick release application for emergencies. Top-stop strength may be reduced from repeated use.

Symmetric Zipper

■ As the shape of the elements are symmetric, you can move the two sliders more smoothly.

Size	Chain Type	The Color of Elements	Closed-End	Open-End	Two-Way Open
5	MGWP	Golden Brass	○	–	–
	MGWPS	Anti-Nickel Silver	○	–	–
	MGWKB	Antique Gold	○	–	–
	MGWTH	Antique Silver	○	–	–
	MGWK	Black Oxidized	○	–	–
	MGWDS	Dull Silver	○	–	–



MGWPC-51 DFW KQ DFW KQ P14W
EL-PWAX SLSH-H

Elements Finish Variation

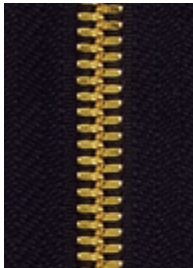

Golden Brass

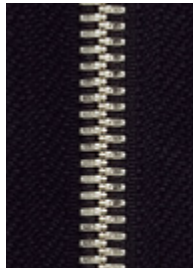

Anti-Nickel Silver

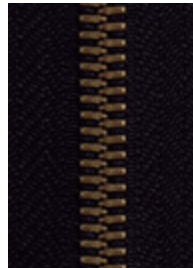

Antique Gold



Antique Silver

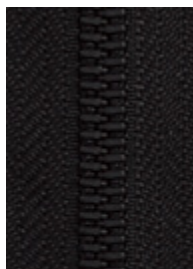

Black Oxidized

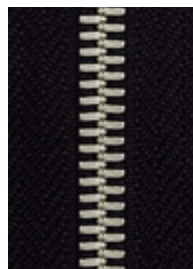

Dull Silver

Fire Retardant Zipper



RGC-56 DA8 O

- The flame-resistant zipper uses fire retardant tape materials.
- Cleared by U.S. Federal Aviation Specification, FAR-25-853(b)

Size	Chain Type	Tape	Closed-End	Open-End	Two-Way Open
5	RG(RGM)	FX19	○	○	-
	RGK(RGMK)				
	RN(RNM)				
10	MG(MGM)		○	○	○
	MGK		○	○	-
	MN				
	MA				

※Chain type "RGM", "RGMK", "RN" and "MGM" are for zippers with double sliders or reverse type zipper.

※Available tape color: #567 only

NATULON®



RGC-56 DA8 O PR14 GREEN-F

- There are two types of NATULON®, Chemically recycled made from chemically recycled polyester (post consumer) and Mechanical recycled made from material recycled PET.

Chemically recycled

Size	Chain Type	Tape	Closed-End	Open-End	Two-Way Open
3	MG	PR12	○	○	-
	MGKB				
	MGTH				
5	RG	PR14	○	○	-
	RGKB				
	RGTH		○	○	○
	RGK(RGMK)				

Mechanical recycled

Size	Chain Type	Tape	Closed-End	Open-End	Two-Way Open
3	YGR*	PBR**	○	○	-
5	RG*	PBR**	○	○	○
7	MG*	PBR**	○	○	-
8	MG*	PBR**	○	○	○

※Chain type "RGMK" is for zippers with double sliders.

※Tape code and chain type vary among the production sites.

※For further information, please contact YKK representatives.

Various Sizes of Coil Zippers

Standard



No.2



No.3



No.45



No.5

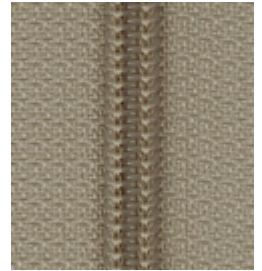

No.8



No.10

CONCEAL®



No.2



No.3



No.5

MINIFA®

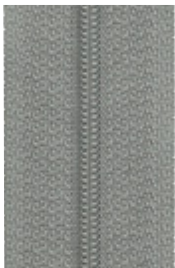

No.0



No.4



No.5

Woven In Type Zipper

FLATKNIT®

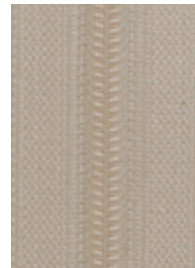

No.25

Regarding the reversed use of coil zippers

Generally, coil zippers (standard) are made so that the element is visible on the outside. However, it can also be used with the element hidden, facing inside.

<Front coil>

<Reversed coil>



※ Depending on the sizes and other conditions, the fasteners may not be available.

Coil Zippers (Standard)

- A coil zipper is made of spiral plastic elements, such as polyester or nylon.
- This is the softest zipper among the three types of zippers.

Size	Chain Type	Closed-End	Open-End	Two-Way Open
2	CF	○	-	-
3		○	○	○
45		○	○	-
5	CIF (CN)	○	○	○
8	CF	○	○	○
10		○	○	○



CIFOR-56 DA9 EQ P16 TO-IPOM

5CIF

- Elements have been changed into bean shape with a hollow. It improved abrasion resistance and made opening and closing operation smoother.

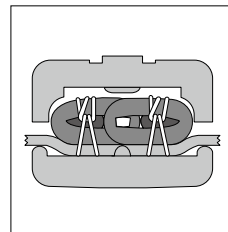

5CNF

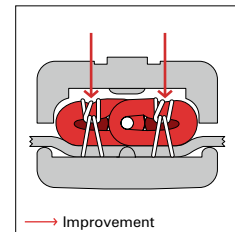

5CIF

Coil Zippers

CONCEAL®



- Zipper with concealed elements.
- It does not disturb the garment's design, so it is best suited for dresses and skirts.

Size	Chain Type	Tape	Closed-End	Open-End	Two-Way Open
2	CH (CC)	BP3	○	—	—
3		P	○	—	—
		BP12	○	○	—
5		PW16	○	○	—

Open Parts



No.3



No.5

- ※BP3/BP12 are knitted tapes, and P/PW16 are woven tapes.
- ※The open parts of No.3 are made of metal while for, and No.5 they are made of plastic.

⚠ P61~P63

CHC-26 DA4Q E BP3 BTM-F P-TOP U19S10

MINIFA®



- MINIFA® zipper is the thinnest and smallest zipper among the YKK products.
- This thin and small zipper is suitable for inside pocket applications.

Size	Chain Type	Closed-End	Open-End	Two-Way Open
0	EF	○	—	—

This zipper (MINIFA®) is suitable for inside pocket applications.

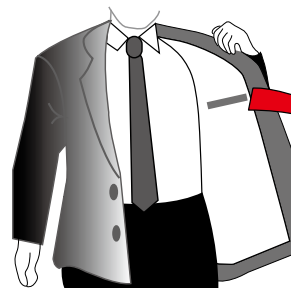

EFC-01 DF3DR E P10 T-0

※MINIFA® doesn't have a top stop. (T-0)

Woven In Type Zippers



EFC-46 DA E PE2

- Zipper with its elements woven into the tape.
- This zipper is thinner than standard coil zipper and is suitable for slacks.

Size	Chain Type	Closed-End	Open-End	Two-Way Open
4	EF	○	–	–
5		○	–	–

FLATKNIT®



FKC-256 DA E BP

- Zipper with its elements knitted into the tape.

Size	Chain Type	Tape	Closed-End	Open-End	Two-Way Open
25	FK	BP/BPS	○	–	–

※Reversed use is not available.

Flex Knit Tape Zippers



CFC-456 DA E BPR2

- The flex knit tape is soft and stretchable, so it can easily be sewn in a curved application without ruining the fabric features.
- It prevents puckering and aligns the elements.
- This item is suitable for use with light and flexible fabric.

Size	Chain Type	Tape	Closed-End	Open-End	Two-Way Open
3	CF	BPR2	○	–	–
45			○	○	–

Elastic Tape Zipper



CNFC-56 DA86 E ELT

- Elastic tape zipper: elasticity rate 10%.

Size	Chain Type	Tape	Closed-End	Open-End	Two-Way Open
5	CNF	ELT	○	○	–

- ※ This zipper does not stretch horizontally.
- ※ Only tape stretches.

SOFLEX®



- A flexible zipper with vertically stretching tape and element.
- It stretches 10% vertically when a force of 1 kg is exerted.

Size	Chain Type	Tape	Closed-End	Open-End	Two-Way Open
3	CS	PUW12	○	-	-
45		PUW14	○	○	-
5		PUW16	○	○	-

CSC-456 DA1 E PUW14 BS-BW P-TOP



Color Variation



※This zipper does not stretch horizontally.
 ※Reversed use is available with size 5.

Coil Zippers

AquaGuard®



- Polyurethane laminated zippers with a special water repellent treatment.
- There are three types of film variations: shiny transparent film, matte transparent film and matte colored film with a high quality appearance.

Size	Chain Type	Tape Type	Closed-End	Open-End	Two-Way Open
3	CFT8	Shiny Transparent Coating	○	○	-
	CFT10	Matte Transparent Coating			
5	CNT8	Shiny Transparent Coating			
	CNT9	Matte Colored Film	○	○	○
	CNT10	Matte Transparent Coating			

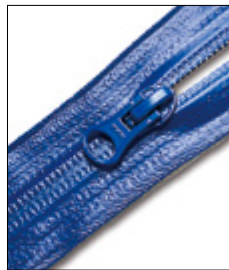

T8
(234 colors)



T9
(39 colors)



T10
(234 colors)

CNT8OR-56 DA8BLH V7 P16N HANTEN
P-TOP REVERSE

Color Variation

- Shiny Transparent Coating (**T8), Matte Transparent Coating (**T10)

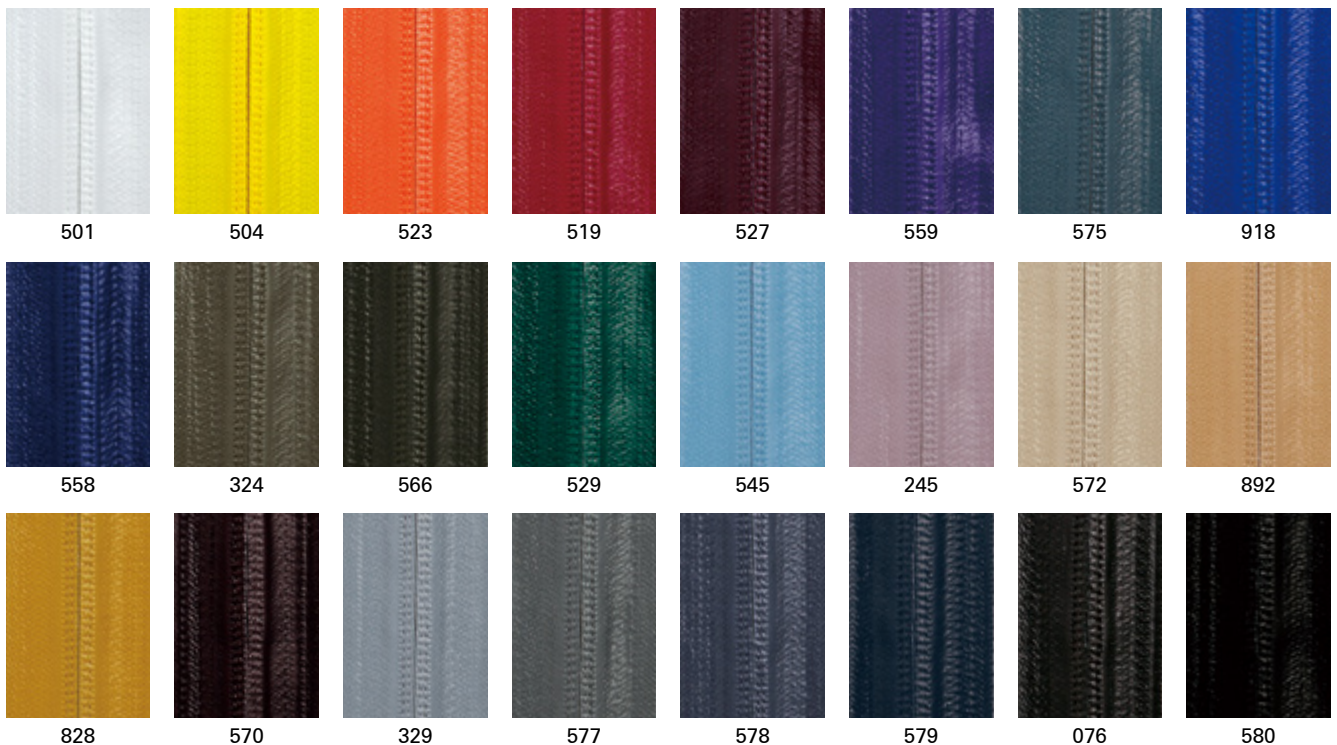

※Reverse usage is the standard specification.

※The zippers which are shown in the above photos are shiny transparent film type.

⚠P51

PRIFA®



PRIFA® zipper is a zipper with colorful tape prints. Patterns, colors and logos can all be created utilizing computer graphics with ink-jet processes.

	Size	Chain	Closed-End	Open-End	Two-Way Open
Standard	3C	○	○	○	—
	45CF	○	○	○	—
	5CN	○	○	○	○
AquaGuard®	3CFT8	○	○	○	—
	3CFT10	○	○	○	—
	5CNT8	○	○	○	○
	5CNT10	○	○	○	○
Cleartape	5CNL	○	○	○	—
NATULON®	3CFH	○	○	○	—
	5CIHE	○	○	○	○
METALLION®	5CNM	○	○	○	○
RC (Racquet Coil)	5RC	○	—	—	—
	8RC	○	—	—	—
CONCEAL®	5CC	○	○	○	—
VISLON®	3VSUPB	○	○	○	○
	5VSUPB	○	○	○	○

CNFC-56 DA86 E P16N
I-YK563 INJET-B REVERSE SLC059

Coil Zippers
PRIFA®

Print Side



Standard (Frontside)



Standard (Backside)

Variation Images

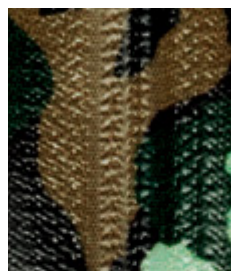

AquaGuard® (T8)



AquaGuard® (T10)



Cleartape



NATULON®

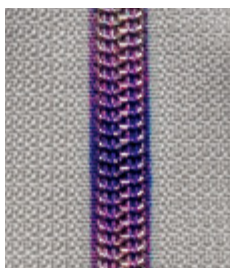

METALLION®



RC (Racquet Coil)



CONCEAL®



VISLON®

※Please contact YKK sales representatives about detailed item information and care instruction for each PRIFA® variations items.

⚠ P65

METALLION®



CNMOR-56 DA86 C5 P16N EL-SIL1

■ METALLION® zipper is a coil zipper that creates a shiny or matte metallic look on a lightweight coil zipper.

■ There are 2 types of elements: shiny type and matte type.

Shiny Type

Size	Chain	Closed-End	Open-End	Two-Way Open
3	CM	○	○	—
5	CNM	○	○	○

Element color	Print side
Silver	EL-SIL1
Gold	EL-GOL1
Nickel	EL-NIC1
Antique Nickel	EL-NIC2
Black Nickel	EL-BLK2
Copper	EL-COP1
Antique Copper	EL-COP2
Light Gold	EL-GOL5
Gun Metal	EL-GUN1

Matte Type

Size	Chain	Closed-End	Open-End	Two-Way Open
3	CV	○	○	—
5	CNV	○	○	○

Color	Size3	Size5
Antique Silver	EL-SIL8	EL-SIL5
Antique Gold	EL-GOL9	EL-GOL7
Matte Black	EL-BLK7	EL-BLK5

Shiny Type

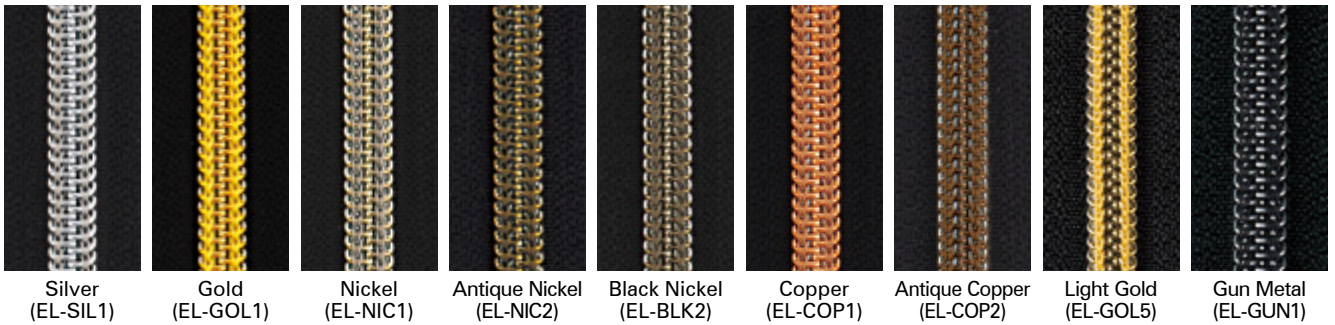

Silver
(EL-SIL1)

Gold
(EL-GOL1)

Nickel
(EL-NIC1)

Antique Nickel
(EL-NIC2)

Black Nickel
(EL-BLK2)

Copper
(EL-COP1)

Antique Copper
(EL-COP2)

Light Gold
(EL-GOL5)

Gun Metal
(EL-GUN1)

Matte Type

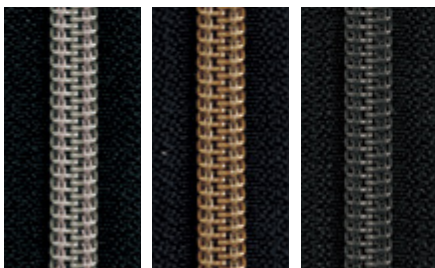

Antique Silver

Antique Gold

Matte Black

※Reverse use is available.

※P-Top will be the standard top stop for open-end and Two-way separator.

※For size 3, the open parts color will be the same as the tape color.

※Please contact YKK representatives if you need more detailed information.

⚠ P54

AUROLITE®



CNPLC-56 DA8LH C5 P16N EL-PL01 P-TOP

- Iridescent effect coil zipper.
- Depending on the membrane and element color, it gives a different impression.

Size	Chain	Closed-End	Open-End	Two-Way Open
3	CPL	○	○	—
5	CNPL	○	○	○

Size	Element color	Print side
3	Black / Gold	EL-PL11
	Blue / Pink	EL-PL12
	Pink / Silver	EL-PL13
	Clear / Gold	EL-PL14
	Natural / Silver	EL-PL15
	Red / Pink	EL-PL16
	Green / Silver	EL-PL17
	Navy / Silver	EL-PL18
	Black / Blue	EL-PL19
	Black / Pink	EL-PL20

Size	Element color	Print side
5	Black / Gold	EL-PL01
	Blue / Pink	EL-PL02
	Pink / Silver	EL-PL03
	Clear / Gold	EL-PL04
	Natural / Silver	EL-PL05
	Red / Pink	EL-PL06
	Green / Silver	EL-PL07
	Navy / Silver	EL-PL08
	Black / Blue	EL-PL09
	Black / Pink	EL-PL10

Coil Zippers
AUROLITE®

Color Variation

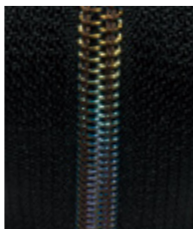

Black / Gold
(EL-PL11)
(EL-PL01)

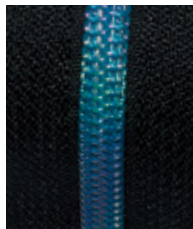

Blue / Pink
(EL-PL12)
(EL-PL02)

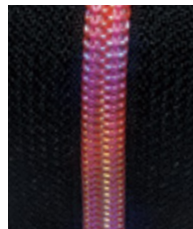

Pink / Silver
(EL-PL13)
(EL-PL03)



Clear / Gold
(EL-PL14)
(EL-PL04)



Natural / Silver
(EL-PL15)
(EL-PL05)



Red / Pink
(EL-PL16)
(EL-PL06)

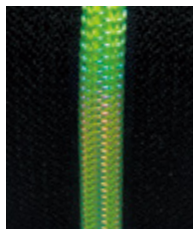

Green / Silver
(EL-PL17)
(EL-PL07)

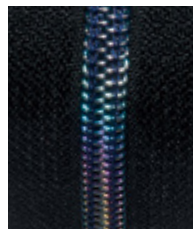

Navy / Silver
(EL-PL18)
(EL-PL08)

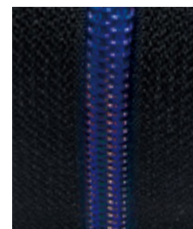

Black / Blue
(EL-PL19)
(EL-PL09)



Black / Pink
(EL-PL20)
(EL-PL10)

※Please contact YKK representatives if you would like detailed information.



Clear Coil Zippers



- Clear coil zipper offers a cool impression and lightweight sensation.
- There are 2 types of tape available. One is made of nylon making the zipper totally clear, and the other is made of standard polyester.

Size	Chain	Tape	Closed-End	Open-End	Two-Way Open
3	CL	P12	○	○	—
		NM	○	—	—
5	CNL	NM2	○	○	—
		P16N	○	○	○

Tape Variation

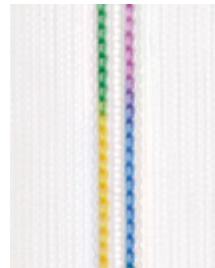

Clear Nylon



Polyester

CNLR-56 DA86 C5 NM2 MC-RAB1

Stich Color Variation



MC-YEL1

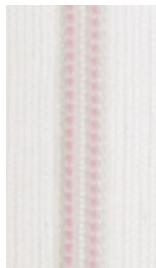

MC-PIK1



MC-PIK2



MC-RED1



MC-ORE1



MC-GRN1



MC-BLU1



MC-BLU2



MC-GRY1



MC-BLK1



MC-RAB1

※Please contact YKK representatives if you would like detailed information.

▲ P54, 59

Stripe Tape Zippers



A clear coil zipper with striped design tape.

Size	Chain	Closed-End	Open-End	Two-Way Open
5	CNL	○	○	○

Stripe Pattern



One Line Stripe



One Line Stripe

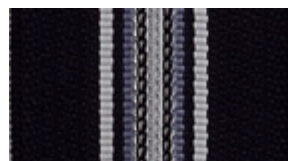

Multi Colors and Lines Stripe



Multi Colors and Lines Stripe

CNLC-59 DS6YG C5 S2A01
HANTEN MC-BL11 P-TOP STC-B05 Y-BTM

⚠ P54, 59

Create-a-Shape Tape Zipper



image

You can customize the shape of this zipper freely.

Available tape colors: 15

Size	Chain	Tape	Closed-End	Open-End	Two-Way Open
5	CNL	PSK	○	-	-

Tape Color Variation



MP01



MP02



MP03



MP04



MP05



MP06



MP07



MP08



MP09



MP10



MP11



MP12



MP13



MP14

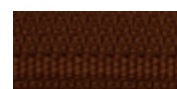

MP15

CNLC-56 DA8MSL1 E PSK MC-GRY5

⚠ P54, 59

NATULON®



■ There are two types of NATULON®, Chemically recycled made from chemically recycled polyester (post consumer) and Mechanical recycled made from material recycled PET.

Chemically recycled

Size	Chain	Tape	Closed-End	Open-End	Two-Way Open
3	CFH	PR12	○	○	○
	CHH(CCH)	PR10	○	—	—
45	CFH	PR14	○	○	—
5	CIHE	PR16	○	○	○

Mechanical recycled

Size	Chain	Tape	Closed-End	Open-End	Two-Way Open
3	CF	PBR**	○	○	—
	CFB	PBR**	○	○	—
45	CF	PBR**	○	○	—
5	CC	PBR**	○	—	—
	CIB	PBR**	○	○	○
	CIF	PBR**	○	○	○
	RCF	PBR**	Only chain shipment		
8	CF	PBR**	○	—	—
	RCF	PBR**	Only chain shipment		
10	RCF	PBR**	Only chain shipment		

※Tape code varies among the production sites.

※For further information, please contact YKK representatives.

CIHEOR-50 RC1 EW PR16 ECOMARK GREEN-F

GreenRise™

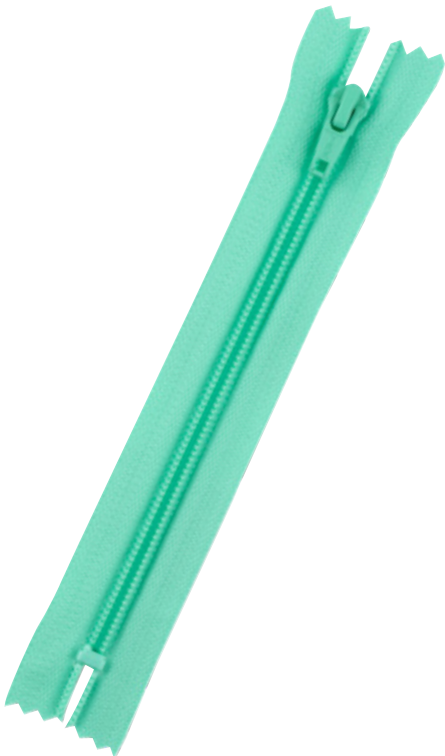

- This zipper is a Partially Plant-Based zipper.
- Reduction of petroleum use.
- Reduction of CO₂ emission in the production cycle.

Size	Chain	Tape	Closed-End	Open-End	Two-Way Open
5	CIGR	PGR16	○	○	○

CIGROR-56 DA86 E PGR16 ECOMARK G-RISE

Reflective Zippers



CIFC-56 DA86 E P16 RFS007D TB-IPOM

Reflective film is used on the tape.

Size	Chain	Silver (REFLX-F)	Semitrans Parent (RFS003D)	Aurora (RFS007D)	Silver Line (ST-SH2)
3	CF	○	○	○	○
45	CF	–	○	–	–
5	CIF	○	○	○	–
	CNF	–	–	–	○

Tape variation

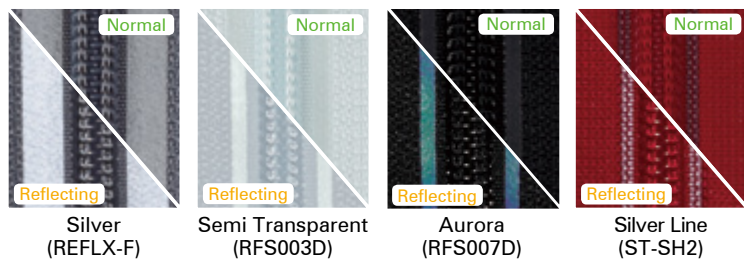

Silver (REFLX-F)

Semi Transparent (RFS003D)

Aurora (RFS007D)

Silver Line (ST-SH2)

Color Combination Coil Zippers



CNFMR-5* DA8LH E DAG8 E P16N COMB-B P-TOP

This is a colorful zipper, with different tape and element colors.

Tape and element in different color

Size	Chain	Closed-End	Open-End	Two-Way Open
3	CF	○	–	–
5	CN	○	○	○

Sewing thread (Single Stitch)

Size	Chain	Closed-End	Open-End	Two-Way Open
3	CF	○	–	–
5	CN	○	○	○

Sewing thread (Double Stitch)

Size	Chain	Closed-End	Open-End	Two-Way Open
3	CF	○	–	–
5	CN	○	○	–

Types of combination



Tape and element in different color

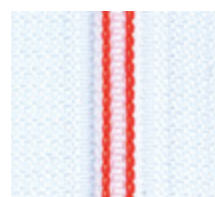

Sewing thread (Single stitch)

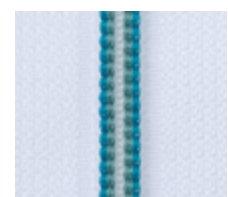

Sewing thread (Double stitch)

※Depending on the colors, there may be a limit on quantities.

▲P54

WOVEN-IN TOUGH ZIPPER



EYLA CHAIN P16 DYED HANK200
EYL ZF5W NL PARTS SP-SIL707

- Flat Appearance & Low element profile
Reduced chain thickness by approximately 15%* less compared to our standard racquet coil zipper.
*This value may vary by chain size, color.
- Abrasion resistance
Precisely engineered to pass the tough abrasion resistance test.
Higher abrasion resistance compared to our standard racquet coil zipper.
- Repairable
New innovative slider system provides zipper pull tab replacement.
*YKK takes no responsibility for the change in quality and performance of its products caused by parts manufactured by a third party other than YKK or processes carried out by party other than YKK.

Size	Chain Type	Tape	Closed-End	Open-End	Chain
55	EYLA, EYLB	P16, P18	—	—	○
85		P17, P20	—	—	○
10	EYLA	P20	—	—	○

※EYLA=Dye chain, EYLB=Solution dye black chain
※Chain and slider supply is only available. (Cut zipper not available)

Size	Slider Body Type
55	ZF5
85	ZF5, ZL1
10	ZL1

Slider Plating Variation



Nickel Silver (NL)



Matte Nickel (NSL)



Black Nickel Light (VL)



Black Nickel Medium (VLB)



Black Nickel Dark (VLD)

Plastic "Snap-in" Part Color Variation



SIL707



GUN704

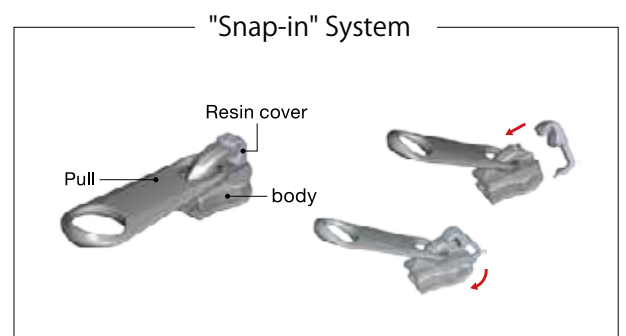

- ※Reverse use not available.
- ※Enamel Painting is not available.
- ※Please contact YKK representatives if you need more detailed information.

Coil Zippers
WOVEN-IN TOUGH ZIPPER

Racquet Coil Zipper



- The Racquet Coil “RC” Zipper.
- Especially designed for luggage and backpack where resistance to abrasion is a must.
- This zipper was precision engineered to fulfill the strength.

Size	Chai	Closed-End	Open-End	Chain
5	RCF	—	—	○
8	RCF	—	—	○
10	RCF	—	—	○

※Tape code varies among the production sites.
 ※For further information, please contact YKK representatives.

05 RCF CHAIN P16R

Various Sizes of VISLON® Zippers

Standard



No.3

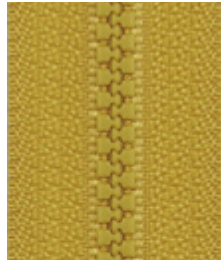

No.4

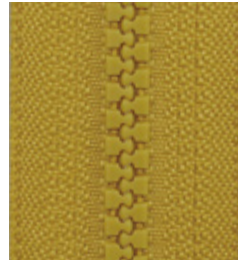

No.5

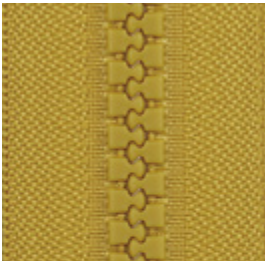

No.8

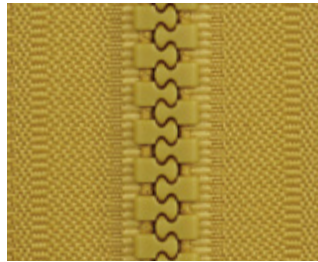

No.10

METALUXE®

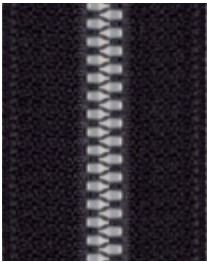

No.3



No.5

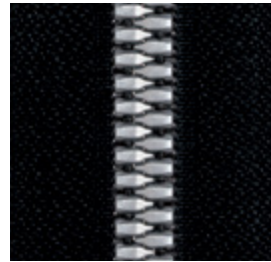

No.8

METALUXE® Fin Type



No.5

METALUXE® Tough

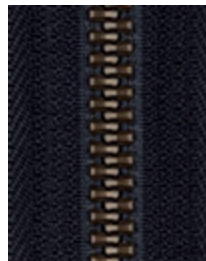

No.5

VISLON® Slim



No.5

VISLON® (Standard)



VSOR-56 DA86 E PT14 NEWKOB4

- The VISLON® zipper is made of injected plastic elements, such as polyacetal resin.
- It is lighter than metal zippers of the same size.

Size	Chain	Closed-End	Open-End	Two-Way Open
3	VS	○	○	○
4		○	○	—
5		○	○	○
8		○	○	○
10	VF	○	○	○
15		○	○	—

VISLON® Metallic Color



VSMVOR-56 DA86 EM PT14 NEWKOB4

- A VISLON® zipper made using metallic color elements.
- Available element colors: 6

Size	Chain	Closed-End	Open-End	Two-Way Open
3	VSM*	○	○	○
4		○	○	—
5		○	○	○
8		○	○	○
10	VM*	○	○	○

Size	Chain	Element Color
3	VSMP	Golden Brass
	VSMG	Gold
	VSMB	Antique Gold
	VSMV	Silver
8	VSMR	Antique Silver
	VSMJ	Matte Black

Size	Chain	Element Color
10	VMG	Gold
	VMB	Antique Gold
	VMV	Silver
	VMR	Antique Silver
	VMJ	Matte Black

Color Variation



Golden Brass (MP)

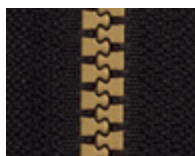

Gold (MG)

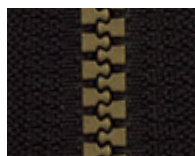

Antique Gold (MB)

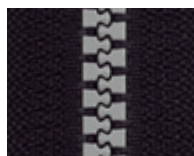

Silver (MV)

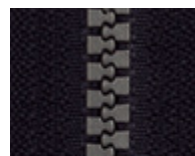

Antique Silver (MR)



Matte Black (MJ)

AquaGuard® VISLON® Zippers



VT10C-56 DA86 E PS14C

- Polyurethane laminated zippers with a special water repellent treatment.
- Metallic color type is available.

Size	Chain	Tape	Closed-End	Open-End	Two-Way Open
3	VT8	PS12A	<input type="radio"/>	<input type="radio"/>	<input type="radio"/>
	VT9	PS14	<input type="radio"/>	<input type="radio"/>	<input type="radio"/>
	VT10	PS12C	<input type="radio"/>	<input type="radio"/>	<input type="radio"/>
5	VT8	P14A	<input type="radio"/>	<input type="radio"/>	<input type="radio"/>
	VT9	PS14	<input type="radio"/>	<input type="radio"/>	<input type="radio"/>
	VT10	P14C	<input type="radio"/>	<input type="radio"/>	<input type="radio"/>
8	VT8	P16A	<input type="radio"/>	<input type="radio"/>	<input type="radio"/>
	VT9	PS16	<input type="radio"/>	<input type="radio"/>	<input type="radio"/>
	VT10	P16C	<input type="radio"/>	<input type="radio"/>	<input type="radio"/>

Combination Pattern

COMBI-1



COMBI-2

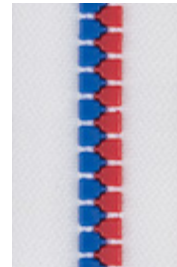

COMBI-3

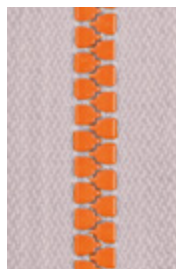

front

back

VISLON® Transparent Type



VSNTC-56 DA8MSL1 C5 PT14 EL-ORE2

■ The elements are made of clear nylon.

Size	Chain	Closed-End	Open-End	Two-Way Open
3	VSNT	○	○	○
4		○	○	—
5		○	○	○
8		○	○	○

Element Color Variation



Clear



Semitransparent
(EL-HAN)



Green
(EL-YEL2)

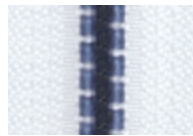

Carbon Blue
(EL-BLU2)

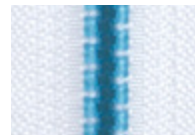

Blue
(EL-BLU3)



Orange
(EL-ORE2)



Brown
(EL=BRW1)



Black
(EL-BLK1)



Gray
(EL-GRY1)

※Other colors are also available.

⚠P59

VISLON® Slim



VHC-56 NA EW P12 N-ANTI NC-F06

■ Thinnest, lightest and the most flexible VISLON® type zipper.

■ 5VH chain thickness is about 75% of 5VS chain and even thinner than 3VS. Chain weight is about 77% of 5VS.

Size	Chain	Closed-End	Open-End	Two-Way Open
5	VH	○	○	○

METALUXE®



VYMVOR-56 DA8VY EM P14A NEWKOB4

- METALUXE® zipper is a VISLON® zipper with a metallic look.
- There are 3 variations: Metal Colors, Metallic Colors, Mirror-like Finish.

Metal Colors / Metallic Colors

Size	Chain	Closed-End	Open-End	Two-Way Open
3	VYM* VYQ	○	-	-
5			○	○
8				

Metal Colors (VYM*)	
Element color	Chain
Golden Brass	VYMP
Gold	VYMG
Antique Gold	VYMB
Silver	VYMV
Antique Silver	VYMR
Matte Black	VYMJ

Metallic Colors (VYQ)	
Element Color	Special Feature
Blue	EL-BLU9
Pink	EL-PIK2
Light Green	EL-GRN6
Emerald Green	EL-GRN5
Copper	EL-COP4
Violet	EL-VIO4

Mirror Like Finish

Size	Chain	Closed-End	Open-End	Two-Way Open
5	VYXM*	○	○	○

Mirror Like Finish (VYXM*)		
Element Color	Chain	Foil Color
Gold	VYXMG	LF-GOL
Silver	VYXMV	LF-SIL
Copper	VYXMC	LF-COP
Hologram	VYXMV	LF-HOL
Chrome	VYXMJ	LF-CRO
Matte Gold	VYXMG	LF-MATG
Matte Silver	VYXMV	LF-MATS

Metal Colors (VYM*)

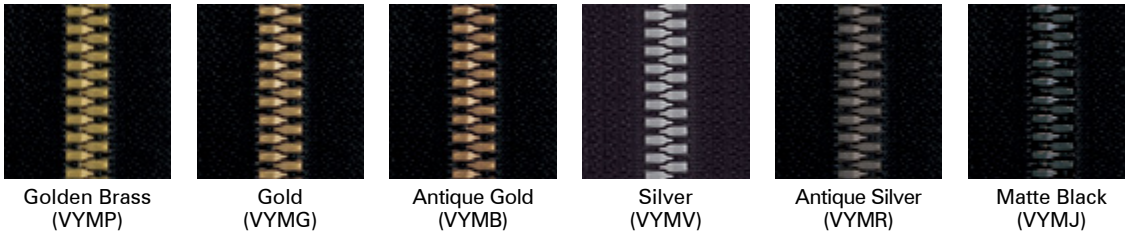

Golden Brass (VYMP)

Gold (VYMG)

Antique Gold (VYMB)

Silver (VYMV)

Antique Silver (VYMR)

Matte Black (VYMJ)

Metallic Colors (VYQ)

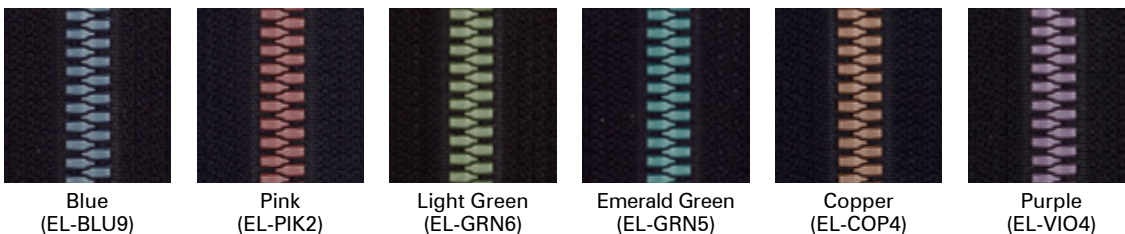

Blue (EL-BLU9)

Pink (EL-PIK2)

Light Green (EL-GRN6)

Emerald Green (EL-GRN5)

Copper (EL-COP4)

Purple (EL-VIO4)

Mirror Like Finish (VYXM*)

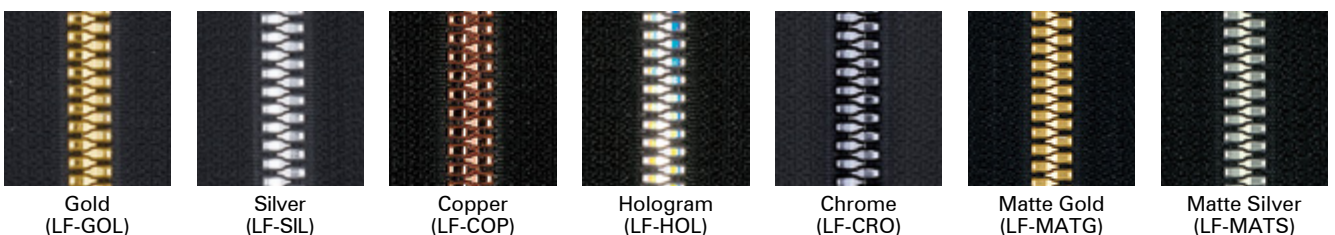

Gold (LF-GOL)

Silver (LF-SIL)

Copper (LF-COP)

Hologram (LF-HOL)

Chrome (LF-CRO)

Matte Gold (LF-MATG)

Matte Silver (LF-MATS)

※Item strength is slightly lower than the standard item, so please do not subject this product to heavy loads.

METALUXE® Fin Type



VYFQC-56 DA9 H3 P14A BS-IPOM EL-SIL6 N-ANTI

- Special element design with extended fin.
- It has higher strength, reduction of slider snagging and the elements coming off, compared to 5VS.
- The slider runs on the fins protecting the tape from abrasion.

Size	Chain	Closed-End	Open-End	Two-Way Open
5	VYFM*	○	○	—
	VYFQ*			

Metal Colors (VYFM*)	
Element color	Chain
Golden Brass	VYFMP
Gold	VYFMG
Antique Gold	VYFMB
Silver	VYFMV
Antique Silver	VYFMR
Matte Black	VYFMJ

Metallic Colors (VYFQ*)	
Element Color	Special Feature
Blue	EL-BLU9
Pink	EL-PIK2
Light Green	EL-GRN6
Emerald Green	EL-GRN5
Copper	EL-COP4
Purple	EL-VIO4
Aluminum Silver	EL-SIL4
Gun Metallic	EL-SIL6



Element

※Open-end can use ez-TRAK® only.

※Regarding element colors, please refer to the color chart of METALUXE® on P.36.

METALUXE® Tough



VDCMBC-51 DF2L2(I) P14A

- High-strength metal look zipper, available in METALUXE® product line.
 - This high-strength is 66% stronger than VISLON® standard*.
 - It is 56% lighter weight than a metal zipper because of the plastic materials.
- ※Compared to No.5 VISLON® (Chain crosswise strength test)

Size	Chain	Closed-End	Open-End	Two-Way Open
5	VDCM*	○	—	—

Element Color Variation



Antique Gold (VDCMB)



Antique Silver (VDCMR)



Metallic Black (VDCMJ)

NATULON®



VSPBEOR-56 DA86 E PR14 GREEN-F NEWKOB4

There are two types of NATULON®, Chemically recycled made from chemically recycled polyester (post consumer) and Mechanical recycled made from material recycled PET.

Chemically recycled

Size	Chain	Tape	Closed-End	Open-End	Two-Way Open
3	VSPB	PR12	○	○	—
4	VSPBE	PR13	○	○	—
5		PR14	○	○	○

Mechanical recycled

Size	Name	Chain	Tape	Closed-End	Open-End	Two-Way Open
3	Standard	VS	PBR**	○	○	○
4	Standard	VS	PBR**	○	○	—
5	Standard	VS	PBR**	○	○	○
	Metallic color	VSM	PBR**	○	○	○
8	METALUXE®	VYM	PBR**	○	○	○
	Standard	VS	PBR**	○	○	○
8	METALUXE®	VYM	PBR**	○	○	—

※Tape code varies among the production sites.
 ※For further information, please contact YKK representatives.

VISLON® Chain Combination Type



VSC-56 DA86 E PT14 COMB-B

This is a colorful zipper that has different color tape and elements.

There are four types of combinations.

Size	Chain	Special Feature	Closed-End	Open-End	Two-Way Open
3	VS	A	○	○	○
4		B	○	○	—
5		C	○	○	○
8		D	○	○	○

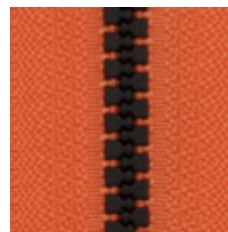

COMB-A

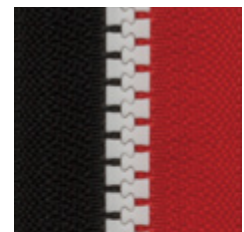

COMB-B

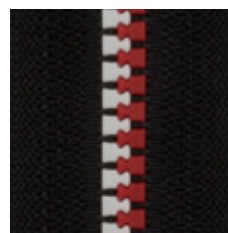

COMB-C



COMB-D

LUMIFINE®

- The luminescent zipper glows in the dark.
- LUMIFINE® glow-in-the dark zipper is now available in six neon color combinations.

Size	Chain	Closed-End	Open-End	Two-Way Open
3	VSK	○	○	○
5		○	○	○



VSKC-56 DA8LH E PT14 EL-YEL4

Element Color Variation

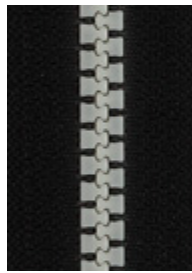

White
(EL-WHT1)

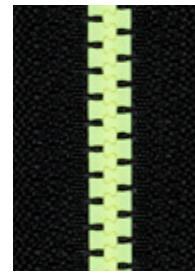

Yellow
(EL-YEL4)

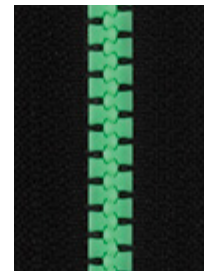

Green
(EL-GRN8)

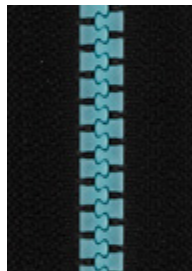

Blue
(EL-BL11)

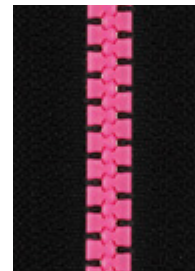

Pink
(EL-PIK3)

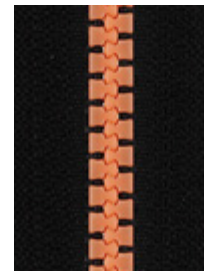

Orange
(EL-ORE4)

VISLON®
Zippers

LUMIFINE®

Under light



When illuminated

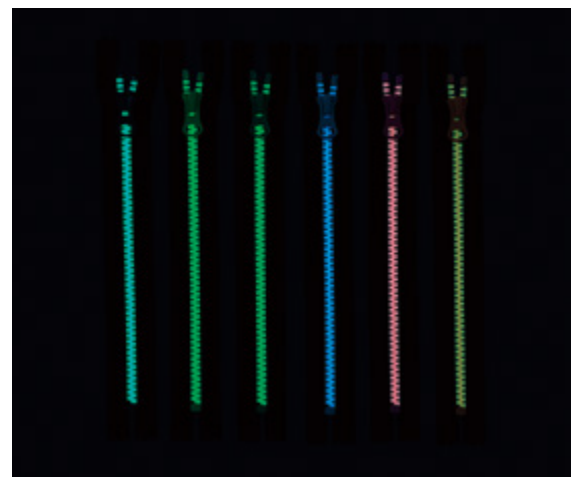

※Brightness and luminosity may vary depending on the size and environment where this zipper is used.

QuickFree™



- The zipper can be opened by simply pulling apart the garment or pulling the zipper chain sideways.
- Enlarged bottom part of slider body allows quick and easy insertion of the separable pin into the slider.

Size	Chain	Tape	Closed-End	Open-End	Two-Way Open
5	VS	PT14	—	○	—

Quick Release

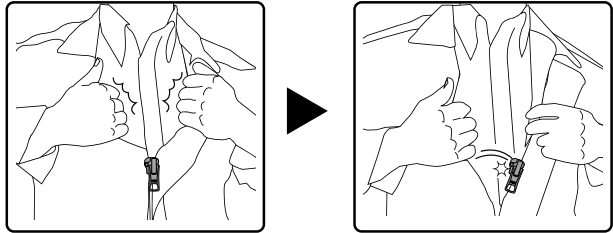

Smart Insertion

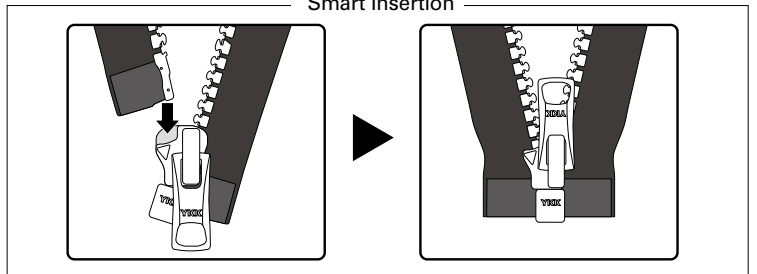

VSOR-56 NAMR2 EW PT14 N-ANTI NEWKOB4 OP-2NAM

click-TRAK®



- Completely new and easy way to close the zipper. Simply position and snap together the open parts.
- Open parts components automatically rotate and engage by pushing open parts down.
- Components are enlarged for easier hand assembly/operation.

Size	Chain	Closed-End	Open-End	Two-Way Open
5	VS	-	○	-

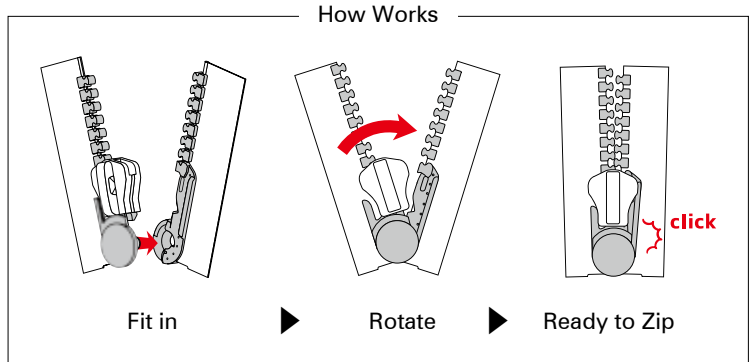

VSOL-56 DAKLH C5 PT14 CK-TRAK
N-ANTI NC-F08 NEWKOB4

VISLON® Zippers
click-TRAK®

How to use click-TRAK®

1. Set

Grip open parts.
Align left & right components.
(Slider must be at the very bottom.)

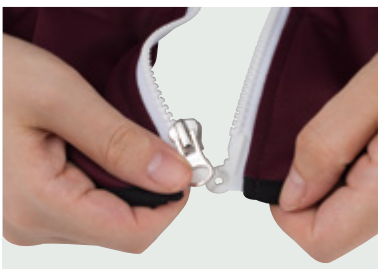

2. Click

Push pull tab & open parts down.
Open parts components will self align / engage.

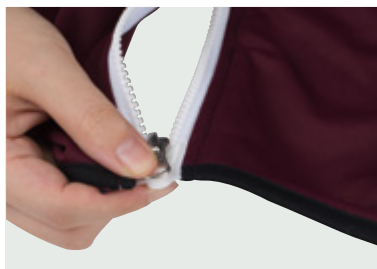

3. Pull up

Pull up on slider tab.
One hand operation possible once open parts components are engaged.

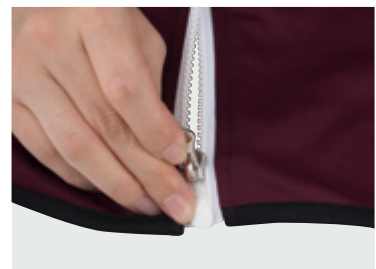

Please visit YKK Fastening website for instructional movie.

AQUASEAL®



VFWBC-101 NFNT580 EN PU23B
AQ-MRK2 BS-NEW2 P-HIMO1
TS-SEAL U25 WBS2BHK

- Combining VISLON® technology with a new innovative seal between the zipper elements, AQUASEAL® zipper allows a smooth and easy operation with perfect protection.
- Size 10, sealed at 0.3 bar water pressure, is individually tested before shipment and laser marked for traceability.

Size	Chain	Tape	Closed-End	Open-End	Two-Way Open
5	VFWN	PU19B	○	○	○
10	VFWB	PU23B	○	○	○
		PU31B	○	○	—

Top Stop

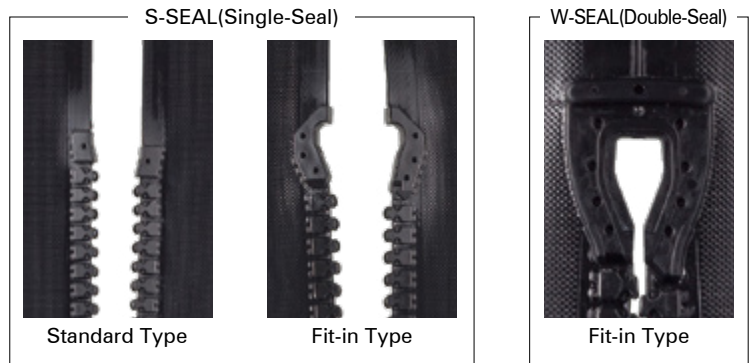

Bottom Stop

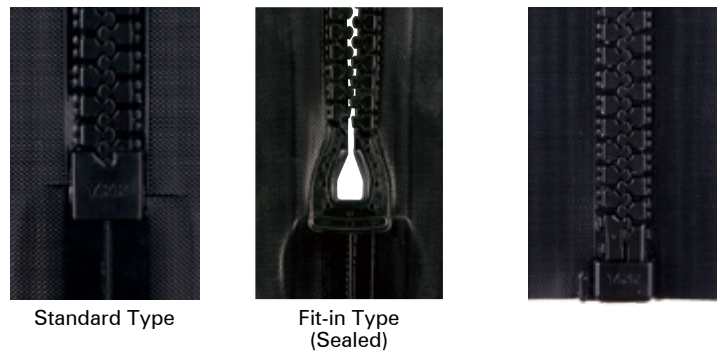

Reinforcement Tape

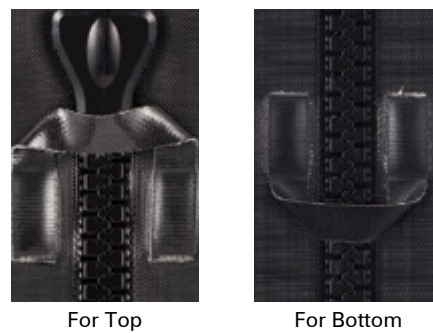

- ※ Airtightness inspection for size 5 is an option.
- ※ Please see P.13 (the page of PROSEAL® zipper) about the airtightness inspection.
- ※ The tape color is black (#580) only.

Dimensions of Zippers and Ways of Measuring

Standards for Measuring Zipper Dimensions

	<p>Closed-End</p> <p>Dimension (A) Slider Top End to Bottom Stop End</p> <p>Top Extension (B) Upper Top Stop End to Cut Tape Tip (to the Top Tip If Jagged)</p> <p>Bottom Extension (C) Bottom Stop End to Cut Tape Tip</p>
	<p>Open-End</p> <p>Dimension (A) Slider Top End to Open Parts End</p> <p>Top Extension (B) Upper Top Stop End to Cut Tape Tip (to the Top Tip If Jagged)</p>
	<p>Two-Way Separator</p> <p>Dimension (A) Slider Top End to Bottom End of Reinforced Tape</p> <p>Top Extension (B) Upper Top Stop End to Cut Tape Tip (to the Top Tip If Jagged)</p>
	<p>Closed-End with Double Sliders (Head to Head)</p> <p>Dimension (A) One Bottom Stop End to The Other Bottom Stop End</p> <p>Top Extension (B) Upper Bottom Stop End to Cut Tape Tip</p> <p>Bottom Extension (C) Lower Bottom Stop End to Cut Tape Tip</p>
	<p>Closed-End with Double Sliders (Bottom to Bottom)</p> <p>Dimension (A) One Slider Top End to The Other Slider Top End</p> <p>Top Extension (B) Upper Top Stop End to Cut Tape Tip (to the Top Tip If Jagged)</p> <p>Bottom Extension (C) Same as Top Extension Length</p>
	<p>With Reversible Slider</p> <p>Dimension (A) Throat of the Slider to Open Parts End</p> <p>Top Extension (B) Upper Top Stop End to Cut Tape Tip (to the Top Tip If Jagged)</p>
	<p>Top-Open</p> <p>Dimension (A) Upper Top Stop End to Open Parts End</p> <p>Top Extension (B) Upper Top Stop End to Cut Tape Tip</p>

Dimension Tolerance and Ways of Measuring

Completely close the zipper when measuring.

The indicated zipper dimension has the specified tolerance as follows:

Product Dimension	Maximum Tolerance
≤ 300 mm	± 5 mm
$300 \text{ mm} < D \leq 600$ mm	± 10 mm
$600 \text{ mm} < D \leq 1200$ mm	± 15 mm
$1200 \text{ mm} <$	$\pm 2.0\%$

(as per JIS S 3015)

※Some special products may not meet the above tolerance.

Methods to Evaluate Zipper Strength

There are various ways to evaluate zipper strength. Basic strengths are determined by the following tests (based on JIS S 3015:2019), then the appropriate application for each item is determined.

※Tensile Testing Machine Conditions — Tensile Speed: 300 mm/min, Clamp Width: 25 mm

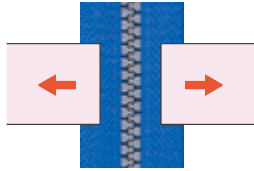

Chain Crosswise Strength (per 2.5cm width)

An engaged zipper chain is pulled crosswise as shown at a constant speed.

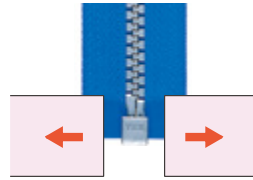

Open Parts Crosswise Strength

Only the open parts are set at the clamp of the tensile testing machine and pulled crosswise.

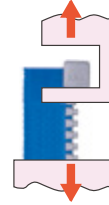

Retainer box pull off Strength

A jig is attached to the retainer box and is pulled in the vertical direction to measure the strength.



Retainer box pull off Strength

The bottom part of one side of the zipper is fixed, the slider is pulled up to the top stop, and then it is pulled hard to measure the vertical pull off strength.

※The standard is 70 N. However, this is limited to items for children. Application of the standard shall be discussed between the supplier and customer.



Top Stop Holding Strength

The lower part of an engaged zipper is held securely, then the slider pulled to the top is further pulled upwards.



Bottom Stop Holding Strength

The slider is pulled down to the bottom stop, and each side of the chain is pulled out to each direction.



Slider Locking Strength

The slider lock is engaged in the middle of a chain, then each side of the chain is pulled out to each direction.

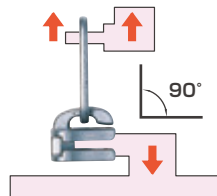

Slider Mouth & Pull Holding Strength (90°)

Tension force is applied to both the pull-tab and the body bottom of an assembled slider. In addition to the shown 90° angle, 45° angle is also tested. (Tensile Testing Machine Speed: 100 mm/min)

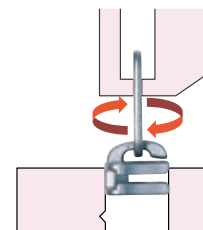

Slider pull-tab twisting Strength

The body of the slider is fixed, and with the pull-tab positioned stood vertically, it is twisted to 180° to measure the strength.

※Twist tester: Twisting speed - approximately 9°/sec

Besides above JIS strength tests, YKK zippers meet BS reciprocating endurance requirement.

Strength Standards (Based on JIS-S2015:2019)

All standard YKK zippers meet JIS requirements

When selecting zippers, please check the strength required for the intended application.

YKK also sets its own quality standards to produce and provide better quality products.

Even items meeting the same JIS class have different strengths per item, so please contact YKK representatives for more detailed specifications.

JIS Classification

Class		Ultra Light	Light		Medium		Medium-Heavy	Heavy	Ultra Heavy
Chain Width (mm)		2.5 - under 4.0	4.0 - under 5.5		5.5 - under 7.0		7.0 - under 8.5	8.5 - under 12.0	12.0
Individual Element	MG		3MG	4MG	5RG	7MG	8MGM	10MG	
	YG		3YGR	4YG	5YG				
	VF		3VS	4VS	5VS		8VS	10VF	15VF
Continuous Element	CF	2CF	3CF	45CF	5CIF		8CF	10CF	
	EF		4EF		5EF				
	CH		2CH	3CH					
	FK		25FK						

※Zippers are classified according to their chain width (i.e. the width of the engaged elements).

※Individual Element: Element type of Metal zipper and Vislon zipper.

※Continuous Element: Element type of coil zipper.

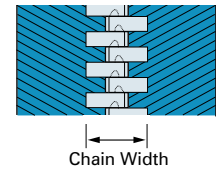

Strength Requirement according to JIS Standard

Strength	Unit	Class		Ultra Light	Light	Medium	Medium-Heavy	Heavy	Ultra Heavy
Chain Crosswise	N	Individual Element	Chemical Fiber Tape	150	230	300	390	490	690
			Chemical Fiber Tape with Reinforcement (for garment requiring higher durability)	300	400	500	600	700	800
			Except for Chemical Fiber Tape	100	150	200	250	300	—
		Knitted Tape							
		Continuous Element	Chemical Fiber Tape	200	250	450	540	590	—
			Except for Chemical Fiber Tape	150	200	200	300	350	—
Separating Unit Crosswise	N	Individual Element		50	70	80	120	150	300
		Continuous Element		-	50	80	120	150	—
Retaining Pull-Off	N			40	50	60	80	120	200
Retainer box pull off Strength	N			This is limited to items for children. Application of the standard shall be discussed between the supplier and customer.					

Strength	Unit	Class	Slider Types		Light		Medium		Medium-Heavy		Heavy		Ultra Heavy		
			Metal Slider	Plastic Slider	Metal Slider	Plastic Slider	Metal Slider	Plastic Slider	Metal Slider	Plastic Slider	Metal Slider	Plastic Slider	Metal Slider	Plastic Slider	
Top Stop Slider	N		40	30	50	40	70	60	100	80	120	100	200	170	
Bottom Stop Holding	N	Individual Element	Chemical Fiber Tape	15	15	40	30	50	40	80	60	100	100	150	150
			Chemical Fiber Tape with Reinforcement (for garment requiring higher durability)	15	—	40	—	50	—	80	—	100	—	150	—
			Except for Chemical Fiber Tape	15	15	30	30	50	40	80	60	100	100	150	150
		Knitted Tape													
Continuous Element		30	20	50	30	70	60	120	90	150	120	—	—		
Slider Locking	N	Individual Element	15	10	25	20	40	25	50	35	60	50	—	—	
		Continuous Element	10	10	10	10	35	25	50	35	60	50	—	—	
Slider mouth & Pull Holding (90°)	N		60	40	80	50	150	100	170	100	200	150	300	300	
Slider Pull-Tab Twist	N·m		0.15	0.1	0.15	0.1	0.45	0.35	0.7	0.45	0.7	0.6	—	—	

Proper Use of Zippers

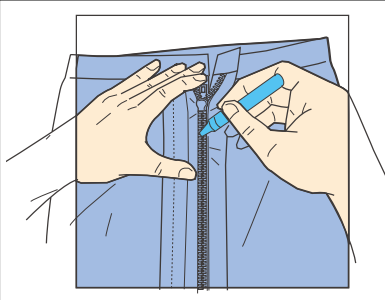

1 Rough Slider Operation

Do not force the slider even if it doesn't move smoothly, or it may cause the elements to misengage.

Apply paraffin or wax on both front and back surfaces of the elements, then move the slider back and forth to regain smooth operation.

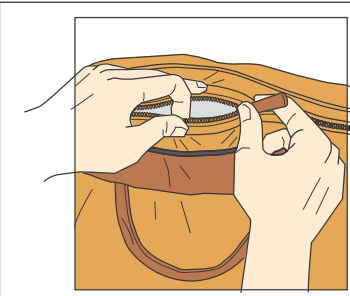

2 Pulled Out Elements

Trying to forcibly close the zipper of an overfilled bag will cause element and tape breakage due to the excess load on the elements.

Reduce the burden by reducing the content of the bag and by bringing both sides of the chain close to each other before closing the zipper.

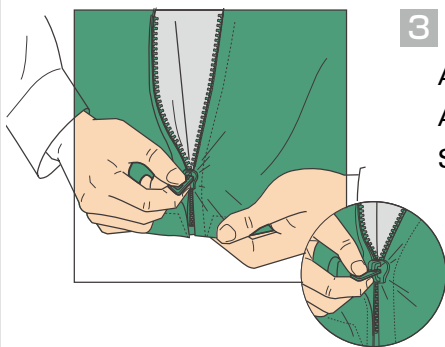

3 Fabric Caught in Slider

A slider may catch the fabric and get stuck during its operation. Avoid forcing it to move or it will worsen the problem.

Slowly move the slider while pulling out the caught fabric

Please allow enough room for the slider to move smoothly when sewing the zipper onto the fabric.

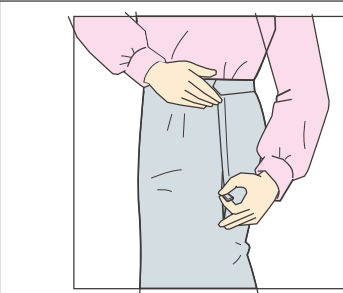

4 When Dressing / Undressing

Make sure to completely open the zipper when dressing / undressing. Dressing / undressing without completely opening the zipper may damage elements / slider function.

When closing the zipper, the slider will move more smoothly if the hook & eye or the top button is fastened beforehand.

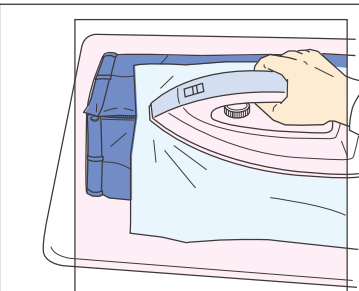

5 Proper Ironing Procedures

Not only the garment fabrics, but also zippers have appropriate ironing temperature according to their materials. Please keep the specified ironing temperature to maintain the zipper quality.

Also make sure to completely close the zipper, lay down the slider pull-tab in the regular position and place ironing fabric on the zipper.

CONCEAL®	160°C
FLATKNIT®	150°C
VISLON®	130°C
Coil Zippers	160°C

(Pressure: 1.5kg, Applied for 10 sec.)

※Direct ironing onto elements or sliders may cause undesirable effects.

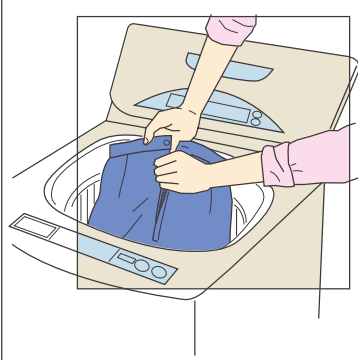

6 Proper Laundry Procedure

Make sure to completely close all the zippers when using the washing / drying machines. Incompletely closed zipper may be entangled with other load and result in element or slider damage or damage on other fabric.

Long or slim slider pull-tab may be caught in the drum holes and break, so the use of a laundry net for those items is recommended.

After the drying process, do not operate the zipper until the garment temperature has cooled down.

Strong alkaline detergent or chlorinated bleach may affect zipper operation. In that case, use softeners, paraffin or wax to regain the smoothness.

Do not presoak garment with zippers in washing solution, or it may cause significant damage.

Proper Use of Open-End Zippers

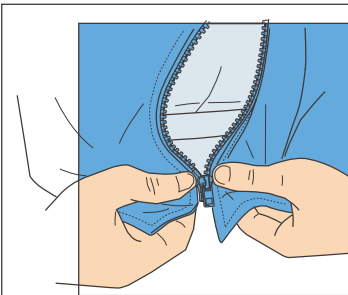

1 Open-End Zipper

◆When closing

1. Completely pull down the slider until it touches the retainer box.
2. Fully insert the insert pin to the box. (Incomplete insertion may cause troubles.)
3. While holding the insert pin side with the right hand, pull up the slider with the left hand.

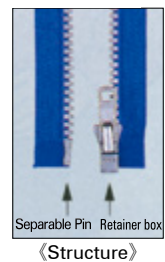

◆When opening

1. Completely pull down the slider until it touches the retainer box.
2. Gently pull out the insert pin with the right hand

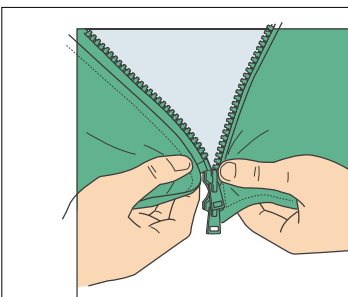
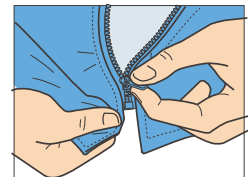

2 Two-Way Open

◆When closing

1. Pull down the upper slider until it touches the bottom slider.
2. Insert the insert pin to the very bottom of the bottom slider. (Incomplete insertion may cause troubles.)
3. Pull up the upper slider with the left hand.

◆When opening

1. Completely pull down the slider until it touches the bottom slider.
2. Gently pull out the insert pin with the right hand

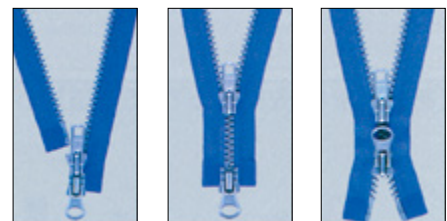

Guide to Effective Use of Metal (Copper Alloy) Zippers

1. When Metals Change Color

Copper alloys generally react with such chemicals as acids, alkalis (bases), oxidizing agents, reducing agents, and sulphides, often forming colored salts. When these chemicals are abundant in adjacent materials, a color change can take place on metal parts, such as elements, sliders, and top and bottom stops or open parts. These chemical reactions occur more readily in hot and humid conditions. For example, if products are pressed after the sewing process with a steam iron and wrapped straight away, or are packed in plastic bags for a long time, this kind of reaction is likely to happen.

Reactive dyed fabric may discolor and sulfur dyed fabric may cause the copper alloy to discolor and stain.

■Woolen Knit Products

When metal zippers are attached to bleached woolen knit products, a color change can take place. Generally, woolen products are bleached by the following methods:

- (1) Using an oxidizing bleach (hydrogen peroxide, etc.)
- (2) Using a reducing bleach (hydrosulphite, etc.)

Furthermore, some woolen products are treated with chlorine oxidizers for a shrink-resistant finish.

If sufficient washing or neutralization has not been made after treatment, especially with hydrosulfite or chlorinated agents, gas (chlorine gas or sulfur dioxide gas, etc.) can be generated. These hydrosulfite and chlorinated agents can also react directly on metal in humid conditions. For example, if woolen products are put into bags immediately after pressing and kept as they are, various chemicals and gases will cause a color change on the metal parts of copper alloy zippers.

Solutions

- Use thoroughly washed, neutralized, and dried woolen fabric.
- Take sufficient time before wrapping after the products are pressed.

■Leather Products

A color change can be caused by residual tanning agents or acids used in the leather tanning process. Tanning agents such as sulfuric acid and other mineral acids, chromium compounds, tannic acids, and aldehyde compounds are used. Since the main ingredient of leather is animal protein, leather cannot naturally or easily rid itself of those tanning chemicals, and a large quantity of chemicals often remain. When such leather comes in contact with metal zippers, it can cause a color change in zippers over time in humid conditions.

Solutions

- Use leather which has been sufficiently washed and neutralized after tanning.
- Conduct preliminary testing.

Changing color of metal parts (under hot and humid environment)

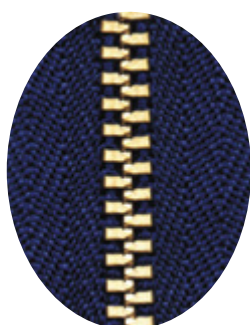

After 72hours

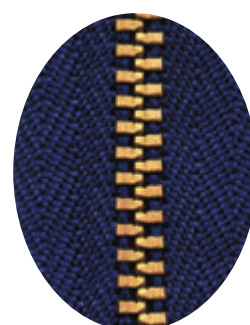

2. When metal zippers contaminate fabric with certain finishes

Chemical reaction caused by acidic substances or oxidizing agents

When acidic substances or oxidizing agents remain in the fabric used for products after dyeing or finishing, they can cause chemical reaction on GKB or GK metal zippers and can stain the portion where the zippers are in contact, especially with white or light-colored fabric. Also, the zippers are likely to cause chemical reactions with reactive dyestuff.

Solutions

- Use material and fabric which has been sufficiently washed and dried after treatment.
- Insert a sheet of paper between the zipper and the garment fabric when packaging.

Transfer of paraffin to fabric, which has waterproof or water-repellent treatment

Metal zipper elements are coated with paraffin to make them work smoothly. When metal zippers are attached to fabric which has waterproof or water-repellent treatment, the paraffin can melt during pressing and transfer to the fabric, staining it.

Solutions

- Press with an iron after inserting several sheets of paper or fabric between the zipper and the material.

Discoloration and color change of cotton products dyed with reactive dyestuff

Reactive dyestuff used for over-dyeing cotton products contains metal ions. Discoloration or color change of the fabric may occur in humid conditions when the dyestuff reacts with copper alloys used for metal zippers.

Solutions

- In case of over-dyeing, dry sufficiently and keep the products in a dry place.
- Avoid sealing the garments in plastic or vinyl bags.
- Avoid warm and humid environments when storing or displaying the garments.

When GKB or GK golden brass zippers are used

The metal parts of surface-treated copper alloy zippers, such as the GKB and KB, can discolor or contaminate adjacent fabric.

Solutions

- Insert a sheet of paper between the zipper and the garment fabric when packaging.
- The possibility of garment contamination can be reduced by specifying a lacquer treatment on the zipper when ordering.

Discoloration of fabric caused by contact with the metal zippers (under hot and humid environment)

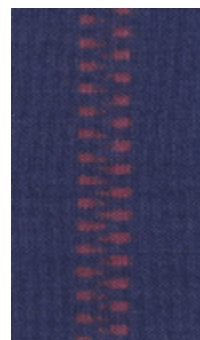
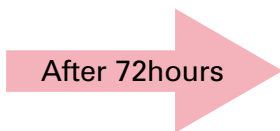

Cautions for Aluminum Alloy Zippers

Aluminum alloy zippers are used in some applications because they are light-weight, but it has some disadvantages due to its nature. Please observe precautions for proper use of the aluminum alloy zipper.

◆ Nature of Aluminum Alloy Zippers

Aluminum is easily affected by moisture, temperature and humidity, and vulnerable to shock, friction, acidic or alkaline element. Therefore, Aluminum alloy zippers are not suitable for harsh treatment such as jeans washing or over-dyeing.

1. Elements Dissolving

Jackets and pants are frequently subject to washing at their finishing process. Aluminum is weak to alkaline and it is reported that strong alkaline solvents may melt the elements of aluminum alloy zipper. Please pay attention when chemicals as metasilicic acid side are used. Also make sure to rinse out those chemicals thoroughly and immediately.

〈Normal Elements〉



〈Dissolved Elements〉



2. Migration and Staining from Aluminum Alloy Zippers

Since aluminum is vulnerable to friction, metal dust is scraped off when operating zippers, which may stain the garment. When this metal dust combines with paraffin wax (which is necessary for smooth zipper operation), it may leave darker stains. Please pay extra attention when applying aluminum alloy zippers to light-colored garments.

※The stain can be removed to some extent by rinsing with any general detergents.

Stain by Aluminum

〈Elements〉



〈1 yen coin (made of aluminum)〉



3. Elements Wearing Out

Aluminum alloy zippers are vulnerable to friction, so its elements may get worn out over regular operation with zinc-alloy sliders with lock, such as DA/DP type. These zippers cannot be used with a copper-alloy slider such as GA/GS type, because the slider is hard and it may significantly damage the zipper elements.

It is recommended to use the item "YAN", which is an anodized aluminum alloy zipper with improved durability. However, we suggest testing before the actual application of those products.

Care for AquaGuard® Zippers

- This zipper is not waterproof/watertight, but water repellent.
- Keep the zipper away from direct sunlight. UV rays may cause a yellowing of the PU (Polyurethane) film.
- The zipper must be completely closed when washing in order to avoid damage.
- Do not iron the zipper.
- A petroleum based dry cleaning solvent is recommended. Chlorine based solvents often result in difficulty in operating the zipper, color runs, or result in cloudy film.
- Tumble drying in a dryer may cause damage to the laminated film and result in the deterioration of the zipper's water repellency.
- Two PU zippers of contrasting color should not be used in a garment if they come into contact with each other for prolonged periods of time (storage, folding, etc.), since this may cause a color run.

Cautions for thermocompression bonding

During thermocompression bonding to fabric, the film is softened. If the slider is moved under this condition, there is a risk that the film on the tape partition will be lost.

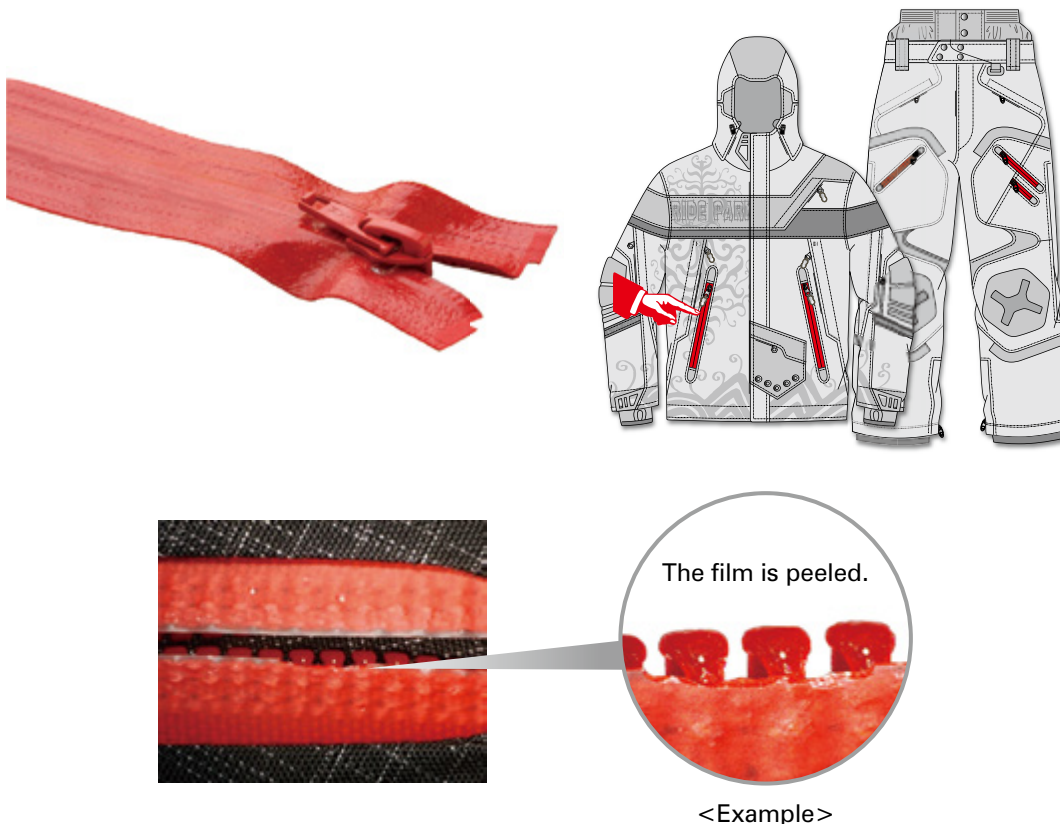

Solutions

- To prevent it, please wait until the temperature becomes appropriate.

Care for AQUASEAL® Zippers

1. Care Instructions

- Please consult with YKK representatives in regard to the usage of AQUASEAL® products.
- Overstretching of the top and bottom stops should be avoided. A reinforcement strap feature is available.
- Slowly move the zipper when operating. Angular pulling may cause element mis-engagement and may result in poor waterproof performance or damaged zippers.
- Folding or crushing the zipper may affect its performance.
- Regular cleaning with fresh water and use of a suitable lubricant is advised in order to prevent damage to the tape and seals.
- Store away from heat and moisture.
- Do not dry clean or machine wash.
- Prevent solvents and adhesives from adhering to the elements.
- Plastic sliders, due to their material characteristics, may become damaged when they are exposed to a strong impact, so please handle them carefully.

2. Attachment

- ① Sewing: In order to prevent the entry of water through seams made by sewing machine, both the front and back faces of the seams must be blocked with seam tape or something similar.
 - ② Gluing: It will depend on the compatibility of fabric, zipper tape and glue.
 - ③ Hot melt: Thermosetting tape is also available.
 - ④ Welding: Can be welded at high frequencies (welder) and using heat (hot air).
- ※We recommend that you attach products to fabric materials such as PU and PVC fabrics.
※Please carefully check compatibility of the product and fabric when attaching using adhesive or via hot melt or welding.
※For details on attaching products, please contact YKK representatives.

3. Maintenance

- Regular maintenance, such as cleaning, is recommended for maintaining products' waterproof features.
 - We offer the "ZIP TECH™" which is dedicated lubricant for AQUASEAL® for maintenance purposes (sold separately).
 - Insufficient lubricant may be a cause of a decline in waterproof performance, so we recommend applying this regularly.
- ※This only relates to the W-SEAL top stop. (See the figure below for the application position.)
※Applying paraffin (wax) to the elements can maintain zippers to be opened/closed smoothly.



ZIP TECH™

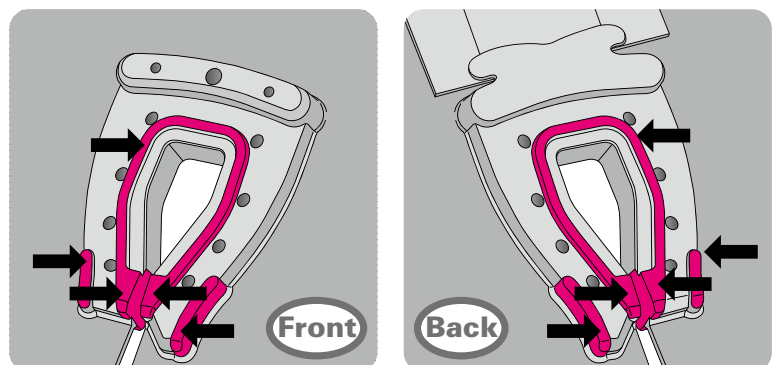

Lubricant application position

"ZIP TECH™" is a trademark of McNett Corp.USA.

Care for PROSEAL® Zippers

1. Care Instructions

- Close the zipper till the slider completely touches the stop to ensure tightness.
- When opening or closing, always ensure that the direction of the pull is along the line of the metal elements. When closing, ensure that both sides of the open zipper are parallel. It is very important to avoid catching undergarments in the elements. If the slider should jam during closure, **DO NOT FORCE IT**. Pull back the slider, remove the obstruction, and slowly attempt to close it again. Excessive force will break the metal chain and destroy the zipper. Also avoid bending the zipper excessively as this will eventually cause the metal chain running inside of the zipper to break.
- As for PVC tape, do not use in an environment where the water temperature is under 10°C, as the PVC will harden and it will affect the zipper's performance.
- Due to the characteristics of PVC, its tightness will deteriorate over time.

2. Cleaning

- After using the zipper, it should be rinsed in clean water. Any objects (sand, mud, etc.) found in or outside of the elements before operating the zipper may result in poor tightness or may damage the zipper.
- Do not dry clean, machine wash, or iron.

3. Maintenance

- Occasional cleaning and lubrication of the elements after use is desirable. Such treatment is especially important if PROSEAL® zipper is used in a dirty or corrosive environment. After rinsing with fresh water, please lightly apply a lubricant such as paraffin to the part of the elements circled in red in the diagram below. After opening and closing the zipper several times, excess paraffin flakes should be removed.

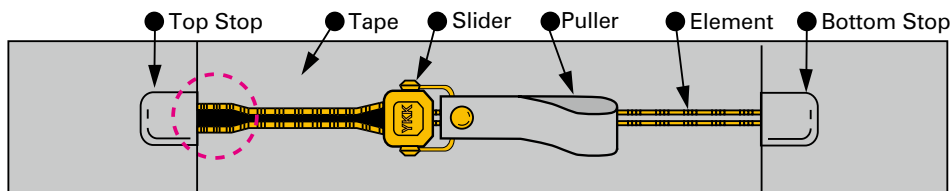

4. Storage

- Store with the zipper completely open, taking care not to bend it. Storage of the zipper in a closed position for long period will cause malformation of the sealing areas. Also, storing it partially opened will cause the zipper to bend. Slight leaks are possible in such cases.
- Do not place any heavy object on the zipper.
- Prolonged contact with such surface materials as PVC or synthetic leather causes the PVC to react with their processing additives, which causes color migration (color transfer). Avoid direct contact when storing by placing a sheet of paper between the zipper and the material.

METALLION®, AUROLITE®, Combination Zippers, Clear Coil Zipper Caution When Washing and Dry Cleaning

Coil zippers where the tape is stitched to the elements after being dyed, such as Metallion®, Combination or, Clear Coil zippers, are more prone to twisting in comparison to standard coils when being subjected to high-temperature drying during washing and dry cleaning.

Supported Items

METALLION®

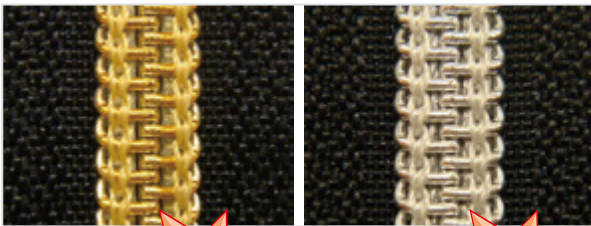

Combination Zipper (COMB-**)



Clear Coil Zipper

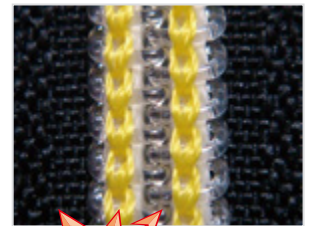

Please be aware of products with different tape, element and stitching colors.

Twisted Condition



Reproduction Test via Dry Cleaning

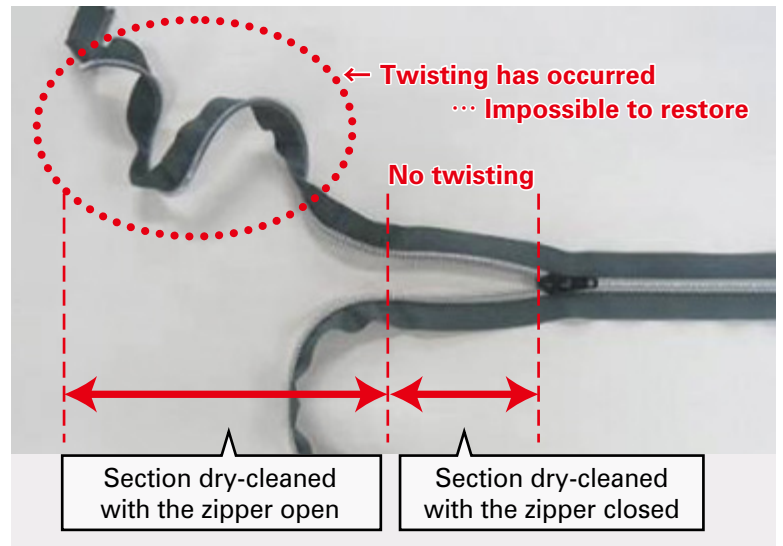

Solutions

Always close the zipper during washing and dry cleaning, and set the temperature to be under 100°C.

※Depending on the shrinkage rate of sewn material, the conditions will change slightly.

Discoloration problems caused by cleaning solvents

Discoloration problems due to the use of cleaning solvents containing large quantities of fluoride ions are known.

Experience suggests that solvents causing discoloration contain hydrogen fluoride (a strong acid), sulfuric acid, etc. These materials cause the following problems:

- ◆ **Discoloration or corrosion of sliders and top and bottom stops made of metal, and fittings**
- ◆ **Decolorization of plastic parts of VISLON® zippers**

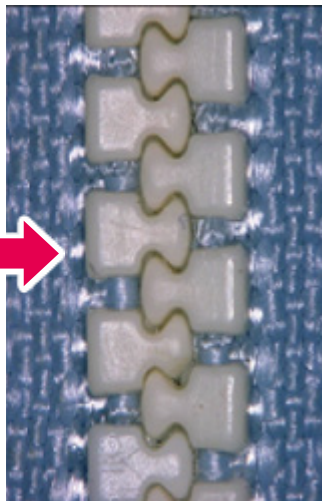
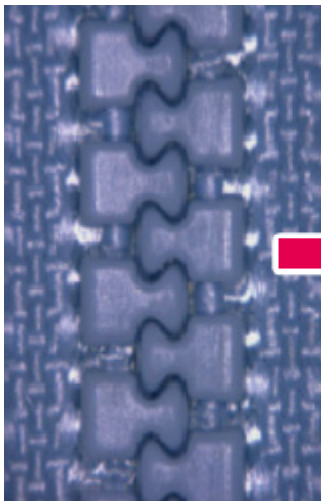
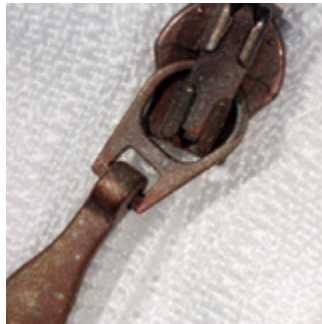

In addition to commercially-sold fluorine solvents, unique cleaning solvents in which detergent is mixed with cooking vinegar - itself a strong acid - are also used. These types of solvent may remain on product fabric and directly or indirectly affect the quality of the zippers used. Problems particularly arise in products comprising light colored fabric.

Garment factories should be instructed to use appropriate cleaning agents that do not include corrosive substances.

If you have any questions related to the appropriateness of cleaning agents, please consult with YKK representatives.

Tips when ironing or pressing

When ironing or pressing garments that uses fastening products, please keep in mind of the followings in order to avoid unexpected damage or deformation.

All zippers

Close the zipper and be sure to use a protective cloth in order to prevent the iron from coming in direct contact with the zipper.

We recommend that you avoid ironing on or around the slider. If it is necessary to iron near the slider ensure the pull-tab is flat and in line with the elements.

Example: Correct direction of the pull-tab

○ Normal position

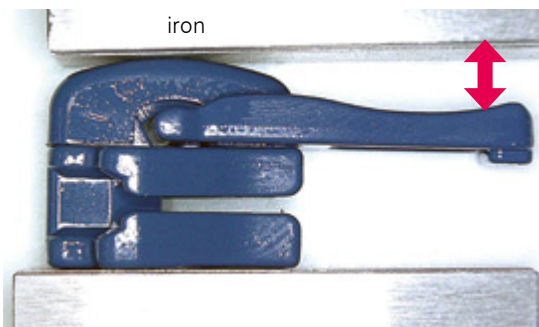

The space is large as compared to when the pull-tab is inversely positioned.

✗ Inverse position

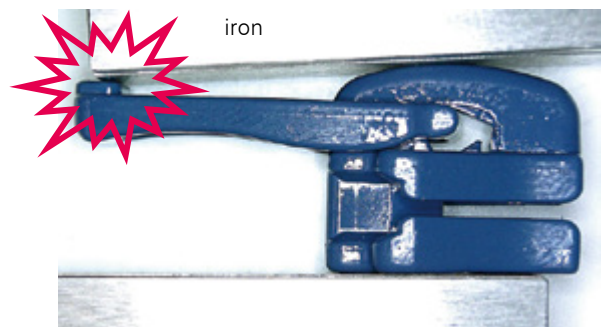

There is no difference in the height between the body and the pull-tab, which tends to place a strain on the pull-tab.

Examples of damaged pull-tab / crushing



Bent pull-tab



Cracked slider

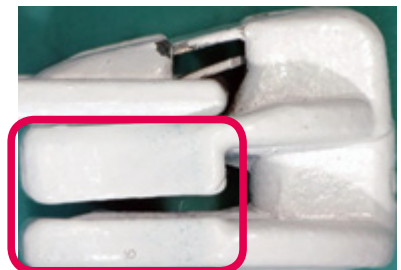

Crushed slider

All-plastic slider

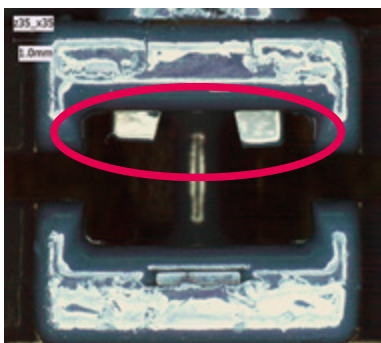

Locked Position

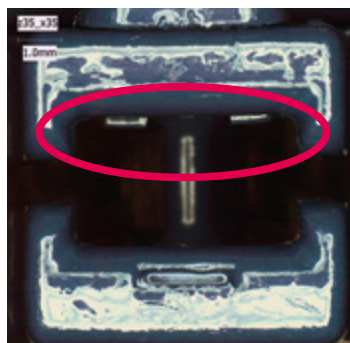

Unlocked Position

If sliders are left in a high-temperature environment with the lock pin raised, gradually the pin may deform if a load is intermittently applied.

The spring section may become deformed and lose its springiness, which may cause poor locking, so care is required.

Precautions on Zipper Use

Tips when ironing or pressing

VISLON® / Coil Zipper

When exposed to a high temperature, the elements may deform or melt. Be sure to use a protective cloth when ironing garments with a zipper. Note that deformation may occur if the top / bottom stop or slider is made of plastic.

Examples of deformation and melting

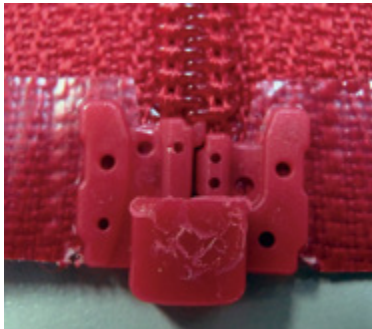

Melted slider

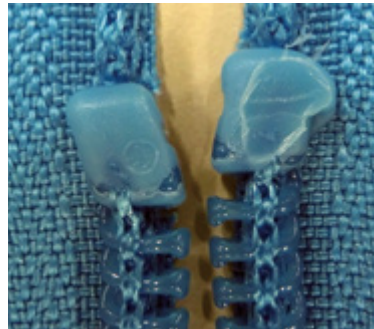

Melted top stop

Maximum iron temperature

(Pressure 1.5 kg, 10 seconds still)

VISLON® Zipper	130°C
Coil zipper	160°C



Melted VISLON® elements

COSMOLON®

Be sure to iron materials from their back surface or use a protective cloth if you need to iron the front surface in order to prevent the iron coming into direct contact with the hooks or loops. Heat and pressure may stretch or crush parts which may lead to poor engagement (decrease in strength).

Cases of elongation and crushing

○ Hook in normal state

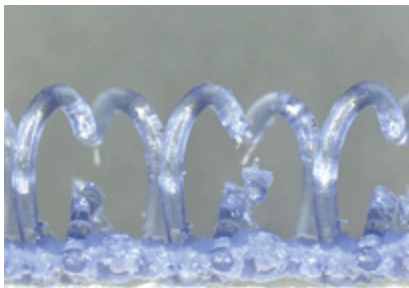

✗ Crushed hook

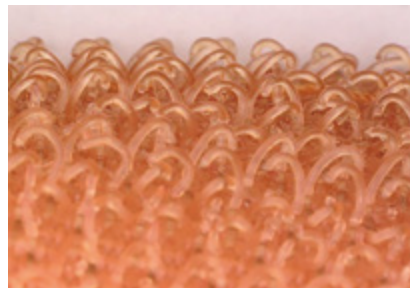

✗ Hook elongation

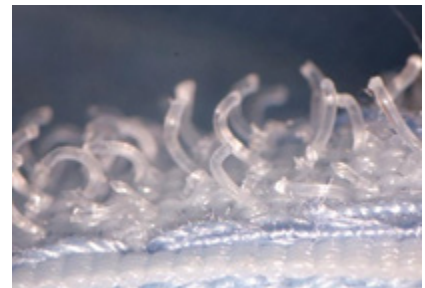

○ Loop in normal state



✗ Crushed loop



The countermeasures and cases introduced here refer to the major problems envisaged in normal usage/ sewing methods. It is not guaranteed that these measures can avoid all problems.

These cases may not apply to zippers used for special purposes or ones that sewn or attached in a special way. Be sure to consult with YKK representatives in advance and conduct full testing on your own in order to judge whether the product can be used or not.

Sliders to which an accessory pull-tab can be attached later

Sliders to which a pull-tab can be attached later include CA, CF, ZA, and ZF.

● CA / CF - types in which a pull-tab can be attached to the small snap hook attached to the slider

Choose a type of pull-tab with an attachment part designed specifically for CA / CF.

Attaching a non-standard pull-tab may damage the swivel hook.

CA [with automatic locking function]

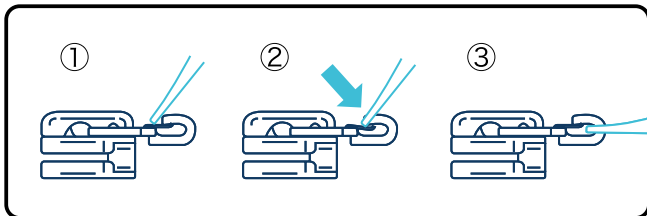

CF [non-lock (free)]

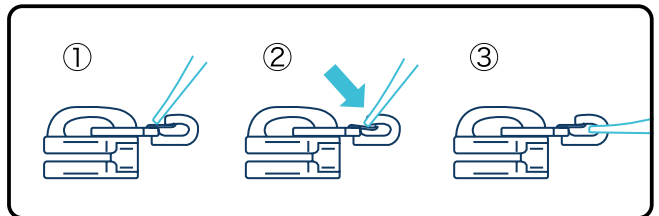

● ZA / ZF - types in which a pull-tab can be attached directly to the slider body -

Choose a type of pull-tab that is compatible with ZA / ZF.

Attaching a non-standard pull-tab may damage the slider.

ZA [with automatic locking function]

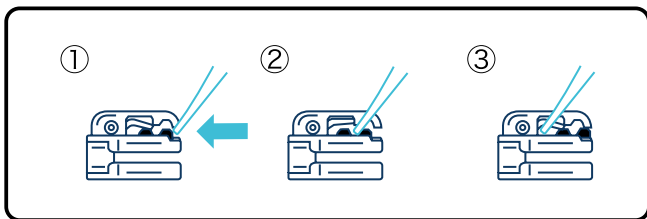

ZF [non-lock (free)]

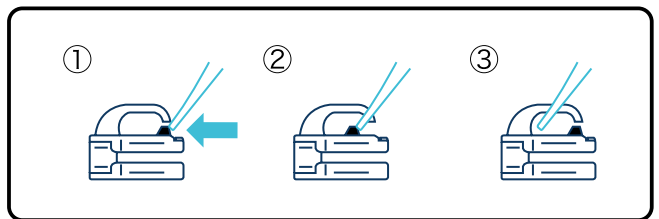

Pull-tab for CA/CF



Pull-tab for ZA

Pull-tab for ZF



※The items above are just examples.

Notes for using sliders to which a pull-tab can be attached later

In addition to the ones listed above, there are some types of sliders to which a pull-tab is attached using a tool such as DADC, DFDC, and DFNT2. Attaching a pull-tab may affect product functions or appearance depending on the pull-tab's dimensions and how it is attached.

Please thoroughly understand the following before use.

- When creating a pull-tab, please make an inquiry to YKK representatives about the shape of the attachment and other issues.
- Do not perform any rework such as removing a pull-tab that has been attached once.
- We do not recommend using coated products (such as some plated products) with a high possibility of peeling off during processing or use.

Please understand YKK takes absolutely no responsibility for the change in quality and performance of its products caused by parts manufactured by a third party other than YKK or processes carried out by a third party.

Remarks for Clear Coil Zippers

- Specify petroleum-type dry cleaning.
- The crosswise strength of the tape is slightly lower than that of standard tape.
- Wash with water temperature under 40°C to prevent the nylon transparent tape from shrinking.
- Cover with fabric when ironing, at a low temperature between 80°C and 120°C.

Remarks for VISLON® Transparent Type

- Specify petroleum dry cleaning only.
- Chain strength is a little weaker than that of the standard item, so it is not recommended for an application with heavy load.

Proper Use / Sewing of 3CF Open-End and Two-way Open Zippers

- 3CF open-end & two-way open zippers are designed for thin and light fabric. To ensure light weight, the open parts of this product are made of plastic, so their strength is relatively low (about half of 5CN, which is generally used in the front opening of general garments).
- As such, please avoid using this product in heavy knit garments, garment with thick fabric, or where heavy load may be applied during garment use. Strong pulling or twisting could result in the breakage of the parts.



Do Not twist the open parts.

Also please note the following precautions for proper handling in order to avoid unnecessary damage or breakage.

1 Zipper Operation

◆ When Closing

1. Make sure the slider is positioned next to the box.
2. Completely insert the pin into the box end.
3. Pull up the slider.

◆ When Opening

1. Pull the slider all the way to the open parts.
2. Draw the separable pin out.

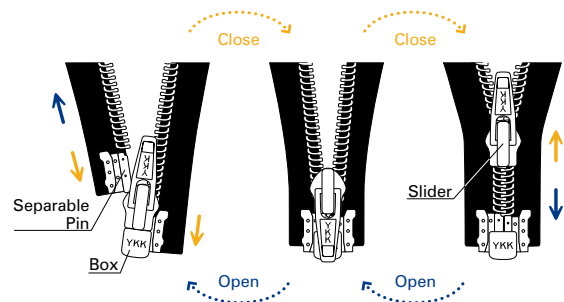

2 Ironing

1. Completely close the zipper and cover with a piece of fabric.
2. Ironing temperature should be below 130°C.
3. Be careful not to accidentally iron the plastic parts.

3 Sewing

- Sew outside the yellow line. (- - - -)
Do Not sew on the plastic part.

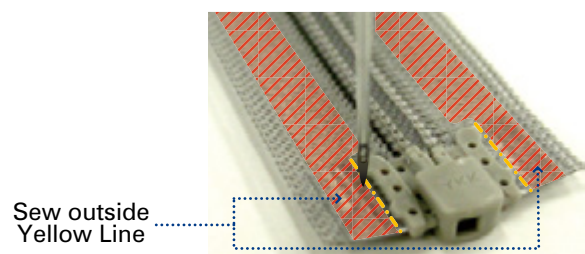

Proper Sewing Procedure for Zippers

Space for Slider

The slider needs some room to move for the zipper to work.

If the stitch is made right by the edge of the elements, the slider will easily catch the adjacent fabric.

Please make sure to allow enough space for slider operation.

Lining fabric especially gets easily caught in the sliders, so sew on the part away from the elements and secure the edges with a sewing machine or prick stitch if a lining is used.

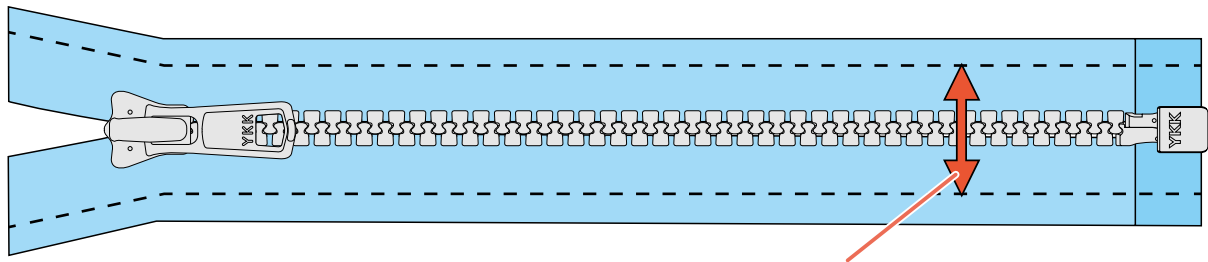

Allow enough space for slider operation.

Sewing Long Zipper

To confirm the compatibility between the fabric and the zipper, tack the zipper onto the fabric before actually sewing on the fabric to check their elongation and so on.

Knit fabric especially requires this preliminary check.

Sewing onto Shaggy Fabric (Fur, Shaggy, etc.)

When applying zipper onto shaggy fabric, place cover fabric such as leather at the edges in order to prevent the slider from catching the fabric.

Sewing Zipper on Pants Flies

Saddle stitch can reduce the load on the bottom stop.

Pants using a short zipper or tight-fitting pants especially place great load to the stop, so applying the saddle stitch is strongly recommended.

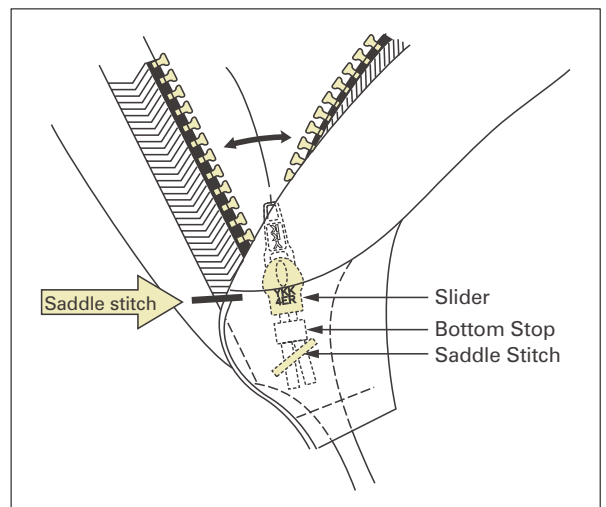

Sewing CONCEAL® (Closed-End) Zipper onto Fabric

Prepare a zipper approx. 30mm longer than the actual garment opening.

Movable Bottom Stop (only 2cc / 3cc)

The movable bottom stop is provided to prevent fraying of the fabric at the opening end. Fraying by the slider movement can be prevented by fixing the stop about 5mm above the opening end point with a special attaching tool.

Precaution for Zipper Sewing

Sewing CONCEAL® (Closed-End) Zipper onto Fabric

When the opening end is already sewn

- Place Body A and B together and sew to the opening end point.
2) Make sure to backstitch at the end point.
3) Mark the end point on the fabrics.
- Put together the body fabrics and the zipper, then mark the end point on the zipper.
- Pull down the slider to the bottom stop, then sew on both sides of the zipper, making sure both markings are met.
2) Use the YKK sewing machine foot, raising the element up and fitting it in the groove of the foot.
- Sew on the zipper to the opening end point.
2) Backstitch the beginning and the end of the stitch.
※Do not cross the zipper stitch lines with the body stitch line; leave room for the slider pull-tab to pass through.
- Bring the slider pull-tab out to the front side, then close the zipper.
- Position the movable bottom stop about 5mm above the opening end point, then secure it using the special attaching tool.
2) The stop prevents the fabric at the opening end from fraying.

Precaution for Zipper Sewing

When sewing the opening end after attaching the zipper to the bodies

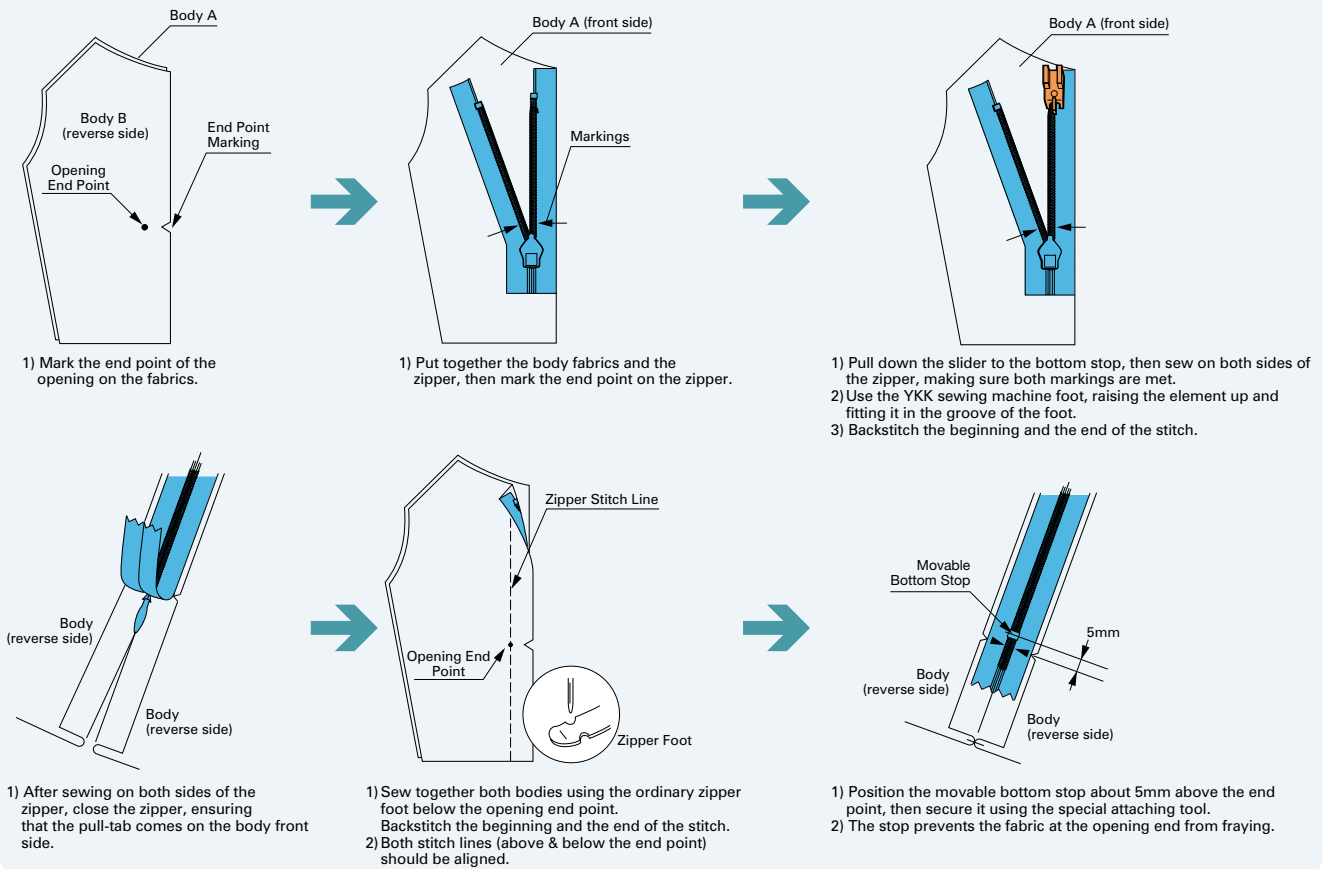

Precautions on Sewing CONCEAL® (Closed-End) Zipper

When CONCEAL® zipper is used in a tight-fitting garment such as a dress. The elements inside the garment may scratch against the user's skin.

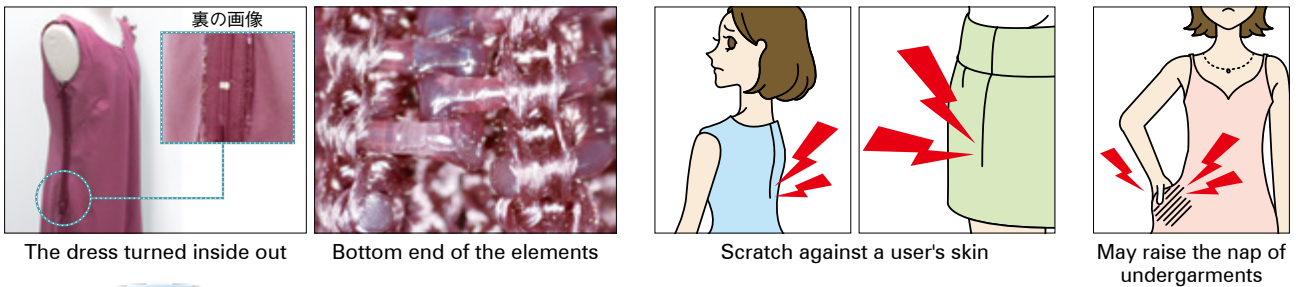

Proper Sewing

Please wrap the part below the movable bottom stop in a fabric backing or put a patch to prevent the elements from scratching against the user's skin.



Fabric Backing



A Patch

Sewing CONCEAL® (Open-End) Zippers

3CH

Sewing on the Retaining Box Side

- Start sewing from the top of the zipper using the YKK sewing machine foot, to about 30mm from the bottom stop.
- Pull up the slider and the retainer box at approx. 30mm from the bottom, and then continue sewing beside the element edge.

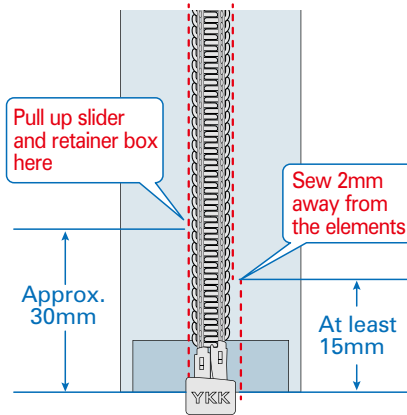
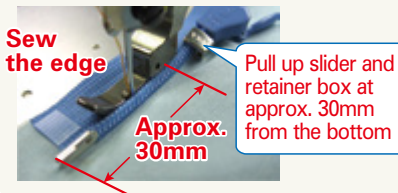

Sewing on the Insert Pin Side

- Start sewing from the top of the zipper using the YKK sewing machine foot.
- At least 15mm from the bottom stop, switch to a narrow foot and sew at least 2mm away from the elements to the bottom.



Attention

Preferred sewing conditions
 Sewing Pitch: 2.5mm
 Backstitch: 1 backstitch
 ※Sewing pitch that is too small and repeated backstitches will cause the tape to break.

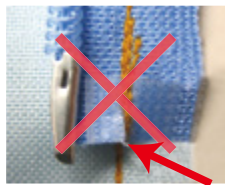

Attention

Sewing on the very edge of the insert pin may make it difficult to insert the pin into the slider.

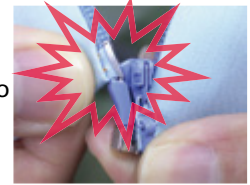

5CH

Sewing the Retaining Box Side / Insert Pin Side

- Using the YKK sewing machine foot, sew right beside the element edge until the point approx. 19~20mm from the bottom.

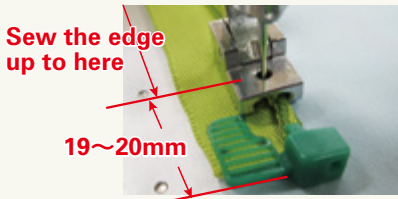

- Switch to a narrow foot and move slightly (over 3mm) away from the elements, then continue sewing to the bottom.

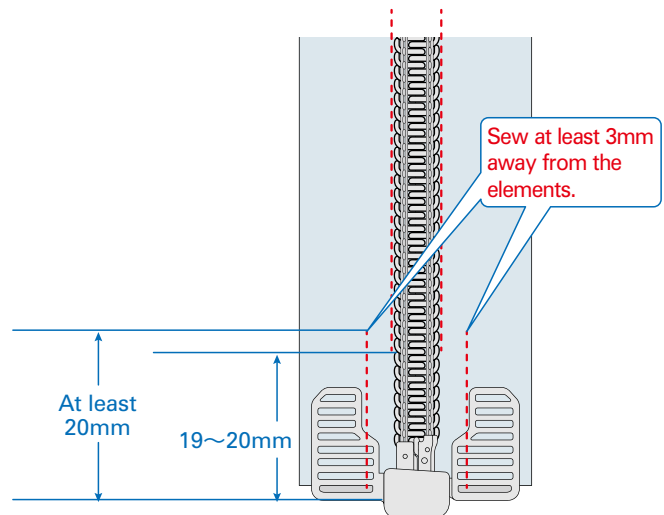
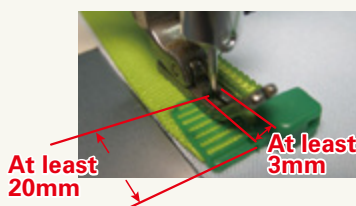

Attention

Sewing the very edge of the open parts may cause the open parts to break.



Precautions for sewing Coil Zippers

- During the spacing process of the coil zipper production, elements are cut and removed from the zipper tape. Occasionally, a half element (remaining after cutting) may be left behind next to the top stops of the zipper, and such cut element may be protruding if the top extension of the zipper tape is bent closely to the top stops during the garment sewing processes.
- The sharp cut end of the protruding element may scratch a user/consumer.



Solutions

- The top extension(s) of the zipper tape should be bent at least 5mm away from the first element (at the top stop position). This would prevent the elements from protruding.

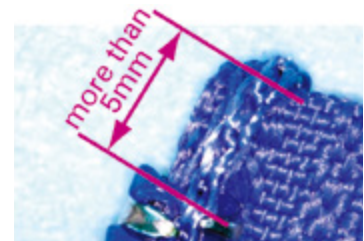

- Selecting the P-TOP (plastic top stops) products can prevent the exposure of sharp cut element, and is highly recommended for infants' / kids' garments.



Warnings and Requests When Sewing the P-TOP

- When stitching the zipper, if the sewing machine attachment or feed dog comes in contact with the top stop and damages it, it could create a jagged edge which can lead to injury.
Example of such damages:

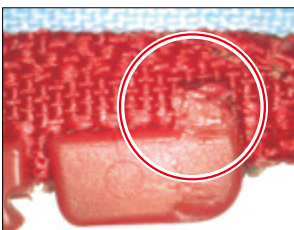

VISLON® (NEWKOB4) damage example

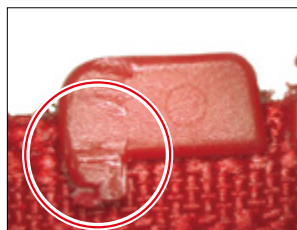

Coil zipper (P-TOP) damage example



Solutions

- Please be mindful that the sewing machine attachments or feed dogs do not come in contact with the top stop when sewing near the top stop or the top extension.

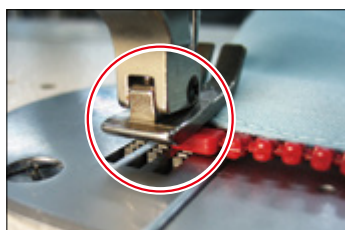

Caution When Sewing PRIFA® Zippers

■ The threads in the printed section could protrude or shift when the rail edge of the slider interferes with the tape.

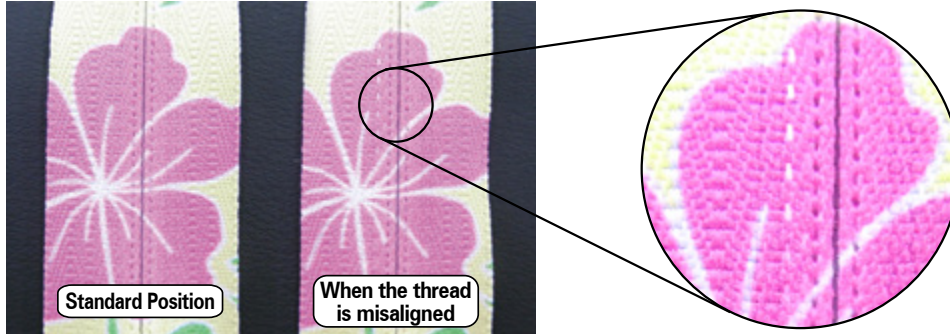

When sewing PRIFA® zipper, the tape thread may get misaligned if excessive force is applied on the print part by the bend created by the slider.

The cause of the tape thread's misalignment:

When sewing with the zipper opened, the sewer will need to move the slider as they sew. The slider will not move smoothly if the stitchings are too close to the elements, and the rail edge of the slider will interfere with the tape, leading to floating or misaligned thread on the print.

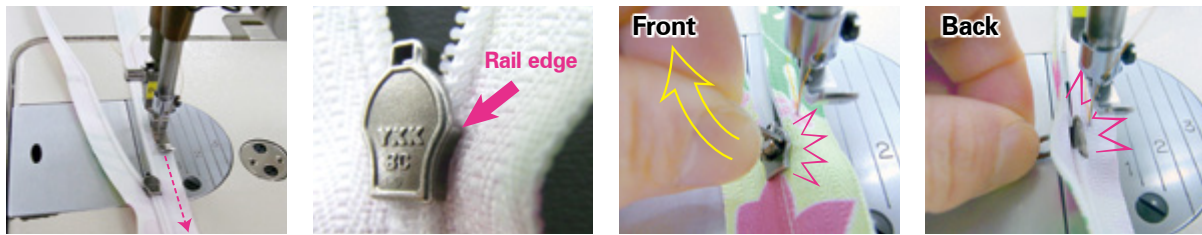

Solutions

- ① Please select an area for proper stitching that allows for smooth slider operation.
- ② When moving the slider, please raise the sewing machine foot.
 - In particular, the slider rail edge tends to interfere when closing the zipper.



Raise the sewing machine foot

Attention

Please refrain from using fixtures such as perforators when moving the slider, as it may cause paint and chrome plating to peel off or create sharp edges.

Zipper Problems and Solutions Q & A

#	Q	A
1	I used the No. 3 zipper with a thick material, which caused punctures and breakage in the open parts.	<ul style="list-style-type: none"> ●When using thick materials, please use zippers above No. 4.
2	The zipper open parts broke.	<ul style="list-style-type: none"> ●For open-end zippers, confirm that the insert pin is firmly inserted when pulling up the slider.
3	Is there anything in particular to be cautious about with the open-end No.3 coil zipper (3CF)?	<ul style="list-style-type: none"> ●The 3CF has fine elements, so even if the insert pin is not inserted firmly into the box, it is possible to pull up the slider by force, in some cases damaging the open parts rib support. This is especially the case if the fabric around the insert pin is ribbed, making it difficult to operate, or the zipper is long, making it difficult to see the ends while operating it. ●When sewing, do not sew over the open parts rib support.
4	The front zipper of a garment comes down on its own.	<ul style="list-style-type: none"> ●Use an automatic slider (DA), which locks when not operated. ●Using a pull-tab that is too big or heavy could lead to the slider being unlocked or breaking while walking.
5	Post-processes such as washing or bio-stonewashing discolor or corrode the zipper, damage its slider or cause it to transmit its color.	<ul style="list-style-type: none"> ●We recommend YG type and GS type zippers, which have superior durability to post-processes. Among the element colors, be particularly cautious with GK, GKB, GTH and GDS. ●In order to avoid secondary damages from the residual chemicals used in post-processes, make sure to adequately neutralize, rinse, and dry quickly.
6	The zipper used on wool and feathered products changed color.	<ul style="list-style-type: none"> ●Wool and feathered products are susceptible to residual chemicals such as bleach, causing the metal part of the zipper to react and become discolored or corroded in storage. Neutralize adequately, and select items not easily susceptible to the influence of residual chemicals such as VISLON® zippers and coated sliders.
7	The metal part of the zipper was discolored.	<ul style="list-style-type: none"> ●Metal parts may corrode depending on the storage condition. There is a risk of the corroded parts staining the product, so products should be kept at low humidity, avoiding hermetically sealed storage in plastic bags or cardboard boxes and allowing some breathability in storage (please be aware of the influence of NOX as well). ●Do not use rubber bands to tie zippers together, since the sulfur in rubber bands can cause the elements to corrode or discolor, or cause the tape to turn yellow. (This problem occurs even when the rubber band is used over a plastic bag.) ●The use of cleaning products containing fluorine, or contact with fabric on which such cleaning products has been used causes metal parts to be discolored. Please be cautious of this. ●We recommend EVERBRIGHT®, which is comparatively resistant to discoloration.
8	The part of the garment that is in contact with a metal zipper became dirty.	<ul style="list-style-type: none"> ●The element surface of the metal zipper is coated with lubricant. The lubricant itself is colorless and transparent, but the metal powder (element shaving) created by opening and closing the zipper, as well as dust, etc. adhering to the lubricant, may contaminate the fabric if these are transmitted along with the lubricant upon contact with the fabric. Be cautious when using metal zippers with light-colored fabrics or absorbent fabrics. When ironing (with steam in particular), be aware that the same effect may occur. ●For storage, line the parts that contact the metal zipper with paper.
9	Skin contact with the zipper caused an allergic reaction.	<ul style="list-style-type: none"> ●Some elements and slider surface types contain nickel. Please select nickel-free products (special specification: N-ANTI).
10	While sewing, the sewing machine needle or attachment damaged the top stop and created a rough edge, causing injury.	<ul style="list-style-type: none"> ●The area around the top extension comes into contact with sewing machine needles and attachments from a variety of directions. In order to prevent damages, lower the starting position of the zipper by 5mm and compare the result. (See p64)
11	When opening and closing the zipper, it does not move smoothly or it catches the fabric.	<ul style="list-style-type: none"> ●When sewing, if the stitching is made too close to the elements, the slider will not have enough space to move, impeding its operation. Be careful to allow enough space (See p51). ●If the zipper catches because the fabric used is too thin or soft, you should put in a stitch or core to reinforce it.

#	Q	A
12	The zipper tape tore from the sewing position and broke.	<ul style="list-style-type: none"> ●The zipper tape is woven, so cutting the thread may cause fraying. Do not cut the zipper tape to reduce fabric pressure, to reduce interference from other parts, etc.
13	The elements warped or melted when I ironed it.	<ul style="list-style-type: none"> ●When applying an iron to the zipper, be sure to cover it with fabric. Be cautious of the zipper's heat tolerance (and the heat tolerance of the product itself). Zipper heat tolerance : CONCEAL® 160°C FLATKNIT® 150°C VISLON® 130°C Coil Zippers 160°C
14	A VISLON® element has broken or cracked.	<ul style="list-style-type: none"> ●If you try to open a slider with lock function by force without using the pull-tab, the elements may get torn off. When opening or closing the zipper, be sure to use the pull-tab. ●The material of the elements, polyacetal (POM), makes the elements susceptible to damage by strong acids. Do not clean the elements by soaking it in bleach, and if exposed to materials such as toilet cleaner or battery acid, be certain to wash it with water immediately.
15	The zipper was bent in dry cleaning.	<ul style="list-style-type: none"> ●Repeated dry cleaning or high-temperature drying without closing the zipper will cause it to bend. Be sure to close the zipper before washing, drying, or dry cleaning. (See p54)
16	The CONCEAL® no longer opens or closes.	<ul style="list-style-type: none"> ●If the slider is pulled up diagonally, the elements will warp and disrupt the interlocking mechanism, and it will break if it is forced up further, making it impossible to open or close. When closing the zipper, first fasten the button/hook, and pull up the slider along the elements so that it doesn't get pulled diagonally. ●Zippers are intrinsically hard to operate where fabric thickness changes, so do not use a CONCEAL® where fabric thickness changes.
17	The seam of a coil zipper for a bag broke.	<ul style="list-style-type: none"> ●There have been instances where seams break due to repeated contact with other parts of the bag, such as shoulder belts. Please be mindful when attaching other parts.
18	When using a pin lock (DP) slider in my pocket, the protruding part hurts.	<ul style="list-style-type: none"> ●Avoid the use of a pin lock slider, and use an automatic lock slider (DA) or non-lock slider (DF) instead.
19	We used an automatic lock slider (DA type) for a product that goes through a washing process, and the slider broke.	<ul style="list-style-type: none"> ●The pull-tab of the slider may break when it gets stuck within the tumbler, and chemical residue in the cover can corrode the slider. Please use the semi-automatic slider (GS), which is more durable and has a more suitable shape.
20	The paraffin melted from the heat from an iron press and blemished the clothing material.	<ul style="list-style-type: none"> ●The zipper elements are treated with paraffin in order to improve its sliding properties. When ironing areas directly touching the zipper, use a slip-sheet or fabric between a material and the iron.
21	Is there something I should be aware of when using a zipper for baby products?	<ul style="list-style-type: none"> ●We provide special products for babies, such as the plastic top stop. Please contact a sales representative.
22	The slider caught the material and tore a hole in it, or the zipper won't close because it caught the material.	<ul style="list-style-type: none"> ●Try to pull the slider the other way, as to loosen the caught material. ※This may cause the pull-tab to break, so do not try to force the slider to move. Instead, try moving it gently.
23	When I sent my clothes off for dry cleaning, the press broke the slider.	<ul style="list-style-type: none"> ●We have provided guidance to the cleaning industry to be careful with the sliders when pressing.
24	When I stored the zipper by tying them with a rubber band, the portion touching the rubber band changed colors.	<ul style="list-style-type: none"> ●The sulfur in rubber bands can cause the element to corrode, discolor, or cause the tape to turn yellow. Please refrain from using rubber bands, and use paper or cotton string instead. The same can occur for Cosmolon® as well.
25	The color of the zipper rubbed off onto my bag.	<ul style="list-style-type: none"> ●Contact with plasticizers, adhesives, and oils can cause the colors to rub off. Please be particularly aware of PVC, synthetic leathers, resin coated fabrics, etc. ●Please store with a slip-sheet.

Snap Fastener and Button Products Three Basic Principles

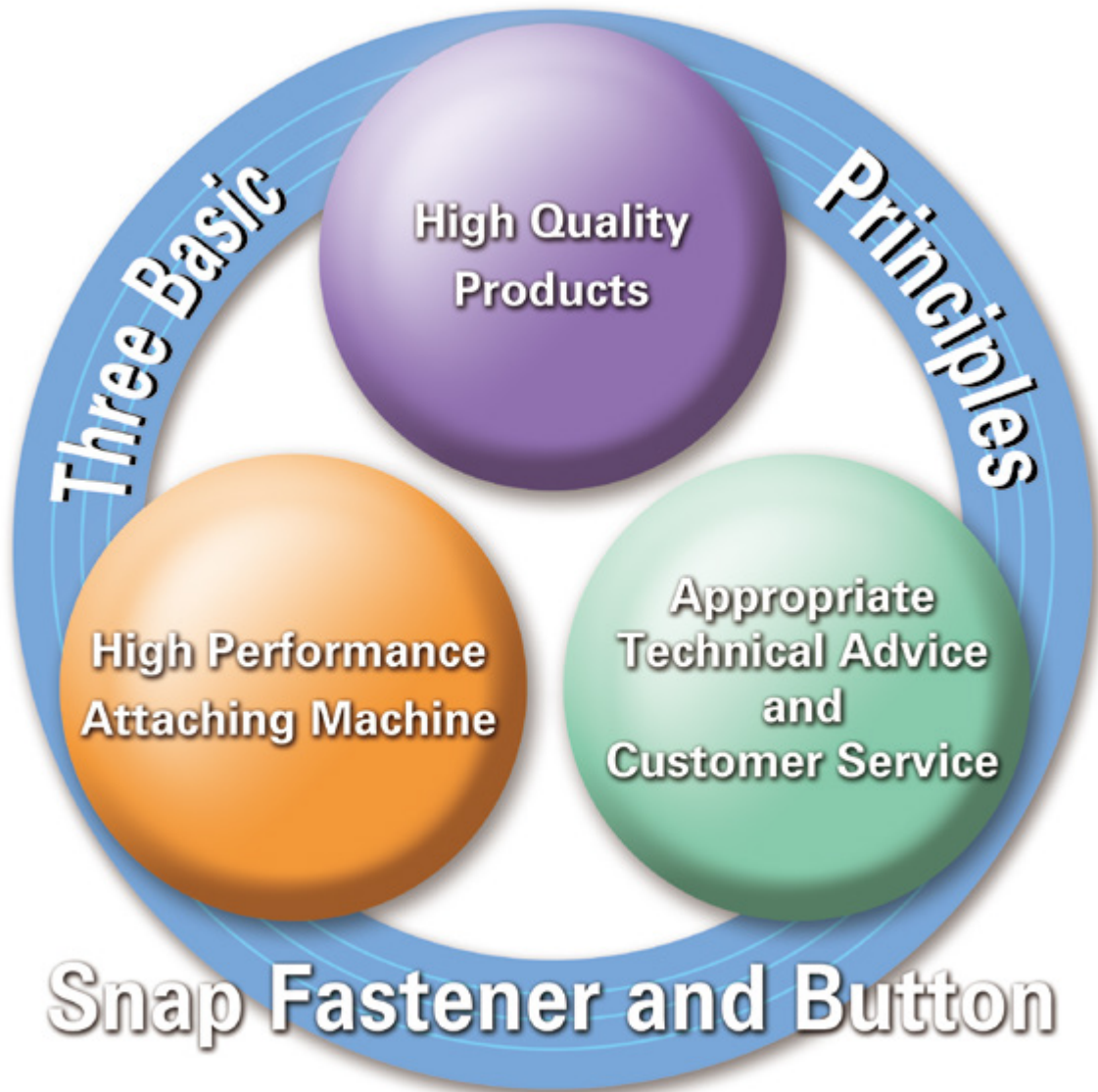

High Quality Products

YKK products are made of highly qualified selected materials under strict production testing.

High Performance Attaching Machine

YKK has a variety of high performance attaching machines, from manual to programmed types. They all possess a compensator device. Please refer to page 66.

Appropriate Technical Advice and Customer Service

With skilled Field Technical Support members, called FTS, appropriate technical advice and follow-up service are available.

Tack Button

Special designs, personalized logos, and variety of finishes are available.

	Closed Top (Plastic Insert)	Open Top	Swivel	Two Prong	
Top Parts					
Top Parts					
Under Parts					
Under Parts	TC21	TC40-001	TC11	TC80	
Size					
Size	22LIGNE (13.9mm)	24LIGNE (15.2mm)	27LIGNE (16.8mm)	30LIGNE (19.0mm)	32LIGNE (20.3mm)

Rivet & Burr

Special designs, personalized logos, and variety of finishes are available.

	SIZE 10 LIGNE (6.4mm)	SIZE 12 LIGNE (7.8mm)	SIZE 14 LIGNE (9.2mm)	SIZE 15 LIGNE (9.5mm)	SIZE 18 LIGNE (11.4mm)	
Top Parts						
Top Parts						
Under Parts						
Under Parts	TC40A (Standard)	TC40A-S (Short)	TC40C (Copper)	TC40A (Standard)	TC40A-S (Short)	TC40C (Copper)

Snap Fastener and Button Products

Snap

- Special designs, personalized logos, and variety of finishes are available.
- Combination of top and under parts can be chosen from our lineup.



S-Spring Snap (Item code: SW)

- Applicable for light-duty to standard garments.

Ring Spring Snap (Item code: SK)

- Applicable for standard to heavy-duty garments.

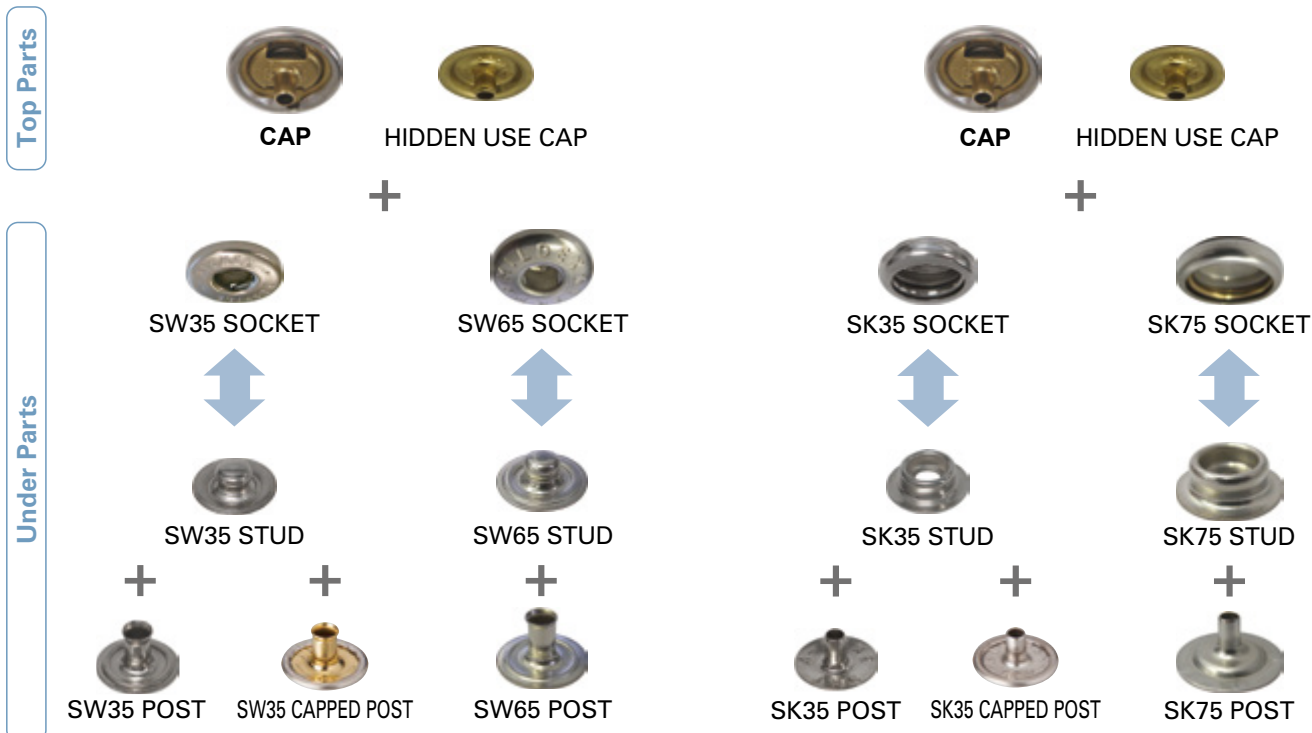

※Hidden use caps are also available for designs with concealed snaps.

Snap Fastener and Button Products

Ring Spring snap (Two-prong) (Item code: SX)

- The two-prong attaching system is one of the most historic methods around.
- With this feature, this snap system possess the means to minimize fabric damage and prevent rotation.

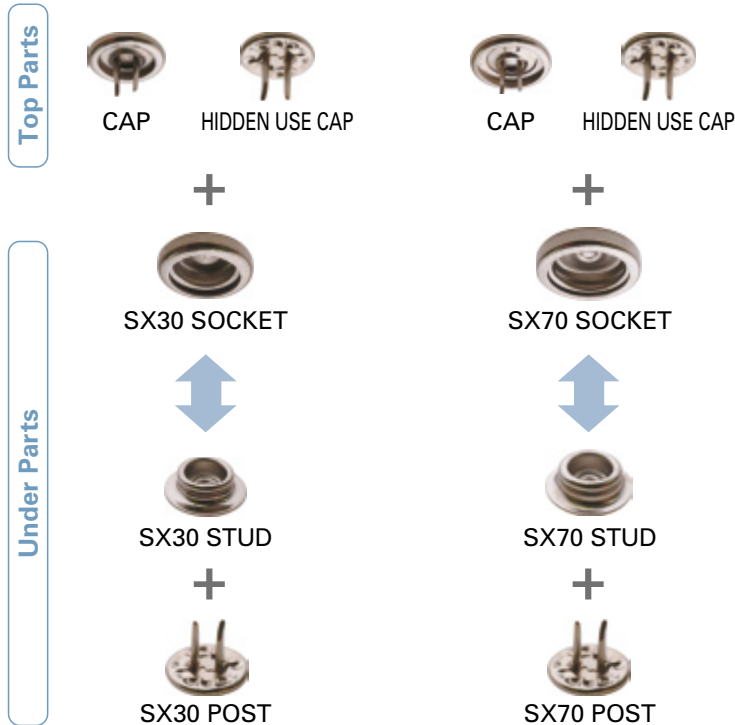

※Hidden use caps are also available for designs with concealed snaps.

Metal-Plastic Composite Snap

- A snap system that shows high performance and durability due to its plastic spring increasing its resistance to abrasion.

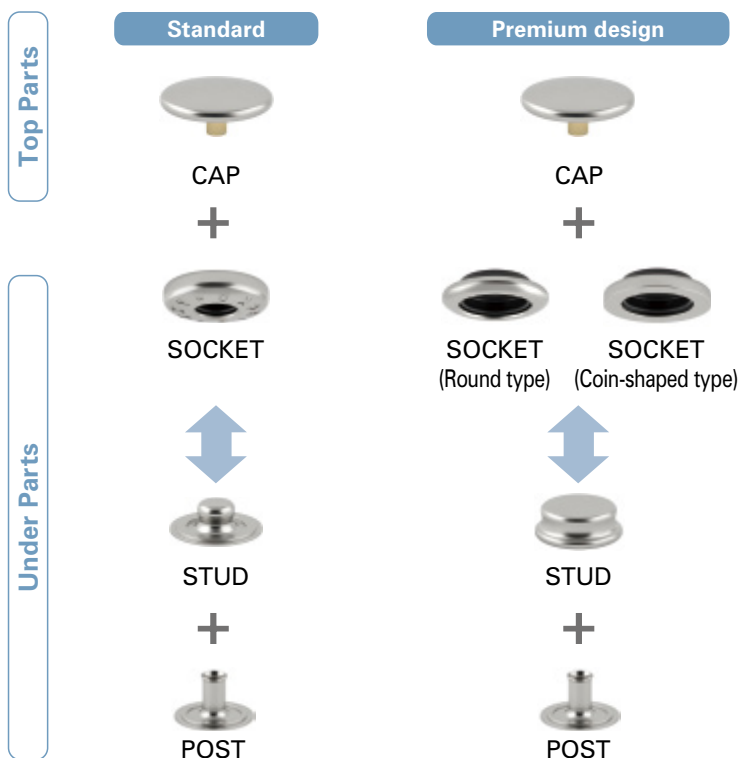

Snap Fastener and Button Products

SNAPET®

- Applicable for elastic / lighter fabric as the prong is less prone to getting caught in the fabric, limiting damage.
- Special designs, personalized logos, and variety of finishes are available.
- Dye-to-match to Prong and Cap are available.

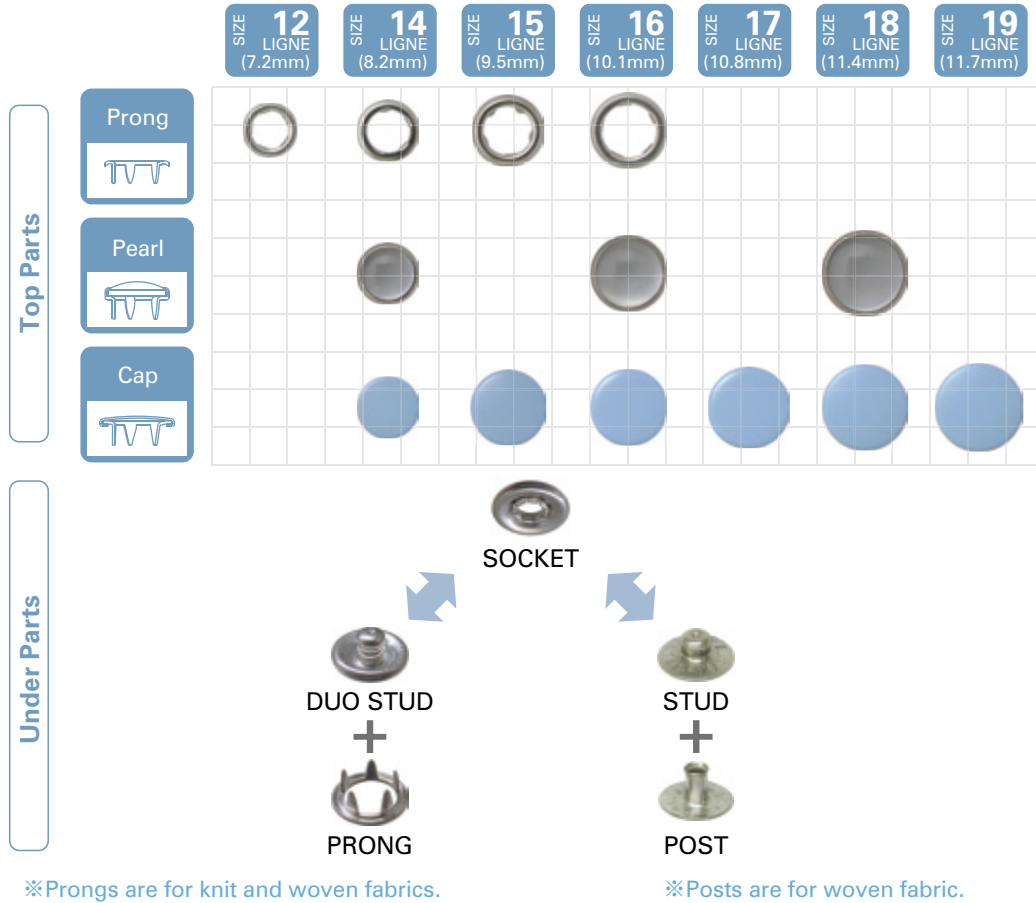

Cap Variations



Plastic Snap

- Good for lightweight application. ■ Dry-Cleanable. ■ High Durability. ■ Self-Piercing.
- Metallic colors are available to match a METALUXE® zipper.



Tape Snap

- SOFIX® snap button is a tape snap which has plastic injected directly onto the tape.
- No need for attaching machines.
- Combination of Socket-Stud tape is available. (Usage example: for comforters, to fasten the ends of the comforter cover.)



Standard



Combination



Fluorescent



Metallic

Snap Diameter: 8mm
Snap Interval: 15mm, 30mm, 45mm, 60mm, 75mm, 90mm
Standard Colors: YKK Asian Group Color Card

Width of Tape: 20mm
Sales Unit: 50m
Special Colors: Dye-to-match is available

[Usage Examples]

For Babies & Children

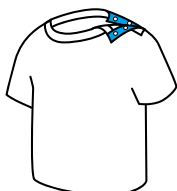

For Sports · Uniforms

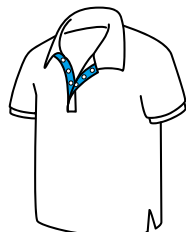

For Linings

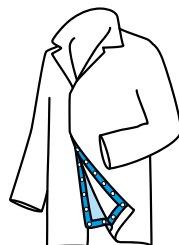

Other Garments

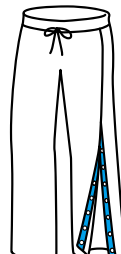

For Comforters

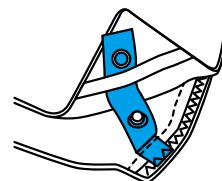

Snap Fastener and Button Products

Metal Sew-On Button

- Light weight press button.
- The hole is designed to prevent it from cutting the thread.
- Special designs, personalized logos, and variety of finishes are available.

PQ
11.5mm~18.0mm

IFG-R

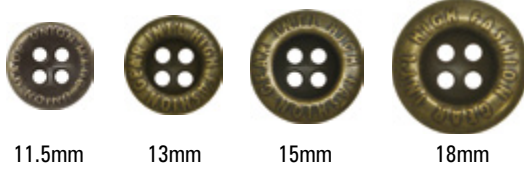

PQ-KN
11.5mm~20.0mm

10 STAR

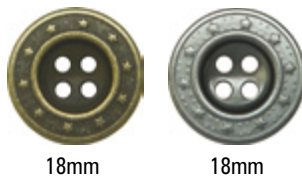

PLAIN

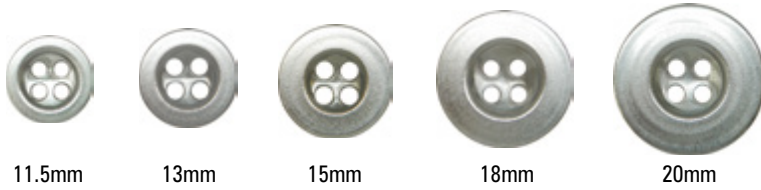

IBS-S



PQ-PN
15.0mm

FUL



Special Color Finish

Matte Color



Equal Color

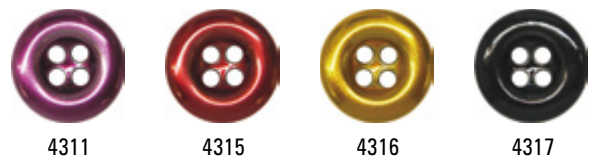

Snap Fastener and Button Products
Metal Sew-On Button

Hook & Eye

■ Suitable for slacks, dress pants and skirts.

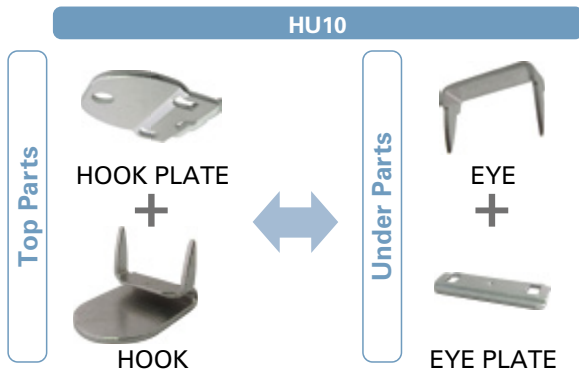

Waist Fastener

■ Suitable for children's pants.

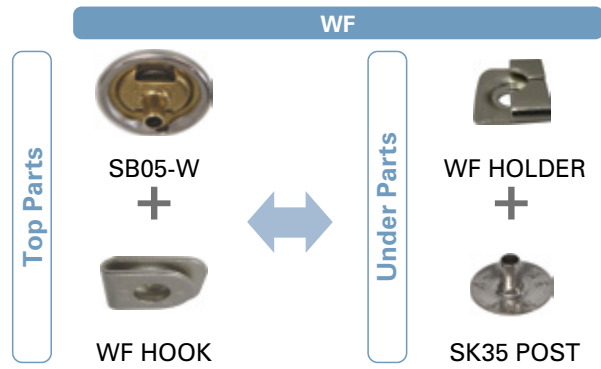

Eyelet Washer

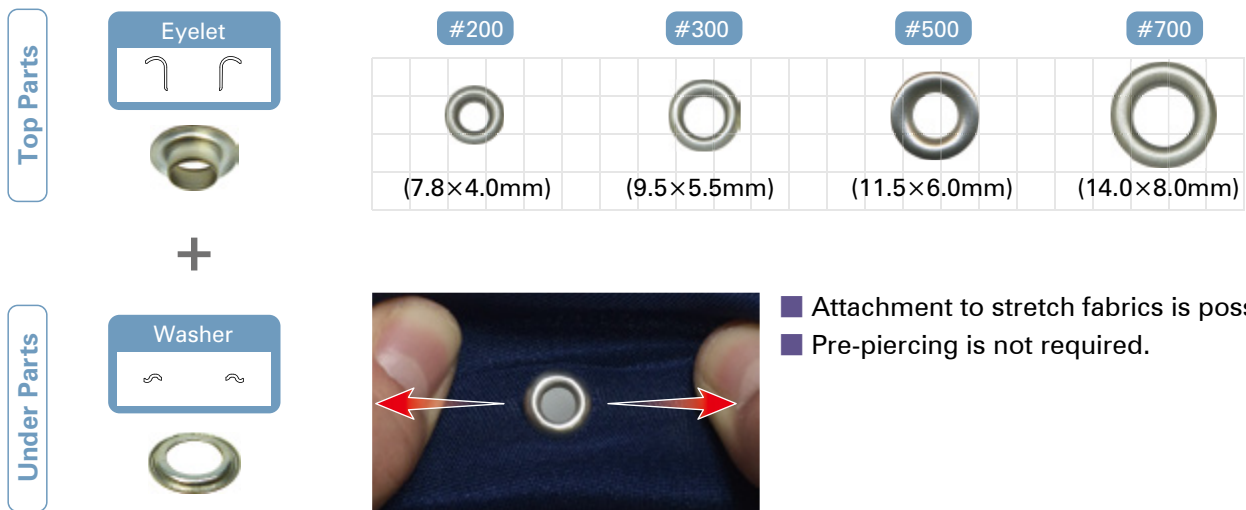

- Attachment to stretch fabrics is possible.
- Pre-piercing is not required.

Attaching Machine

MODEL 131



The Model 131 is a manual foot press type for low-volume production, and it can be used with most YKK® snap fastener items by changing the dies.

Specifications

Dimensions : 1,000mmH×460mmW×425mmD
Std. Equip. : Compensator

MODEL N-6



The N-6 is a semi-automatic attaching machine with powered foot treadle, and it can be used with most YKK® snap fastener items by changing the dies. Marking Light is equipped for easy positioning of attachment.

Specifications

Dimensions : 1,080mmH×340mmW×450mmD
Power : 200W Motor
Electric Source: 100V or 220V Single Phase
Weight : 68kg
Std. Equip. : Compensator / Safety Device
 Marking Light

MODEL N-7



This is an automatic model exclusively for Tack Button, Rivet Burr or Eyelet Washer. Register type is also available to fix logo direction.

Specifications

Dimensions : 1,340mmH×500mmW×560mmD
Power : 300W Motor
Electric Source: 100V or 220V Single Phase
Weight : 130kg
Std. Equip. : Compensator / Safety Device
 Marking Light /
 Automatic Feeder(Register Type)

MODEL N-8



This is an automatic model exclusively for SNAPET® snap buttons or Snap. It comes in a set of two units, one for attaching prong and socket and the other for stud and post (or stud and prong).

Specifications

Dimensions : 1,340mmH×500mmW×500mmD
Power : 200W Motor
Electric Source: 100V or 200V Single Phase
Weight : 110kg
Std. Equip. : Compensator / Safety Device
 Marking Light /
 Automatic Feeder / Gauge Plate

MODEL N-8-3H



This is an automatic model for SNAPET® snap buttons which allows you to choose the attachment order for 3 component SNAPET® snap buttons.

Specifications

Dimensions : 1,340mmH×500mmW×500mmD
Power : 200W Motor
Electric Source: 100V or 220V Single Phase
Weight : 120kg
Std. Equip. : Compensator / Safety Device
 Marking Light / Automatic Feeder
 Gauge Plate /
 Attachment Order Programming

MODEL N-8-4H



This automatic model allows you to program 4 components of SNAPET® snap buttons. Combination of different surface finish of Prong with Socket and Prong with Stud can be registered.

Specifications

Dimensions : 1,340mmH×500mmW×500mmD
Power : 200W Motor
Electric Source: 100V or 220V Single Phase
Weight : 130kg
Std. Equip. : Compensator / Safety Device
 Marking Light / Automatic Feeder
 Gauge Plate /
 Attachment Order Programming

Attachment Guide

Make sure to avoid attachment on uneven thickness, hem, and stitch. Attachment on uneven thickness may result in defective attachment, breakage of fabric, or weak snapping and unsnapping actions.

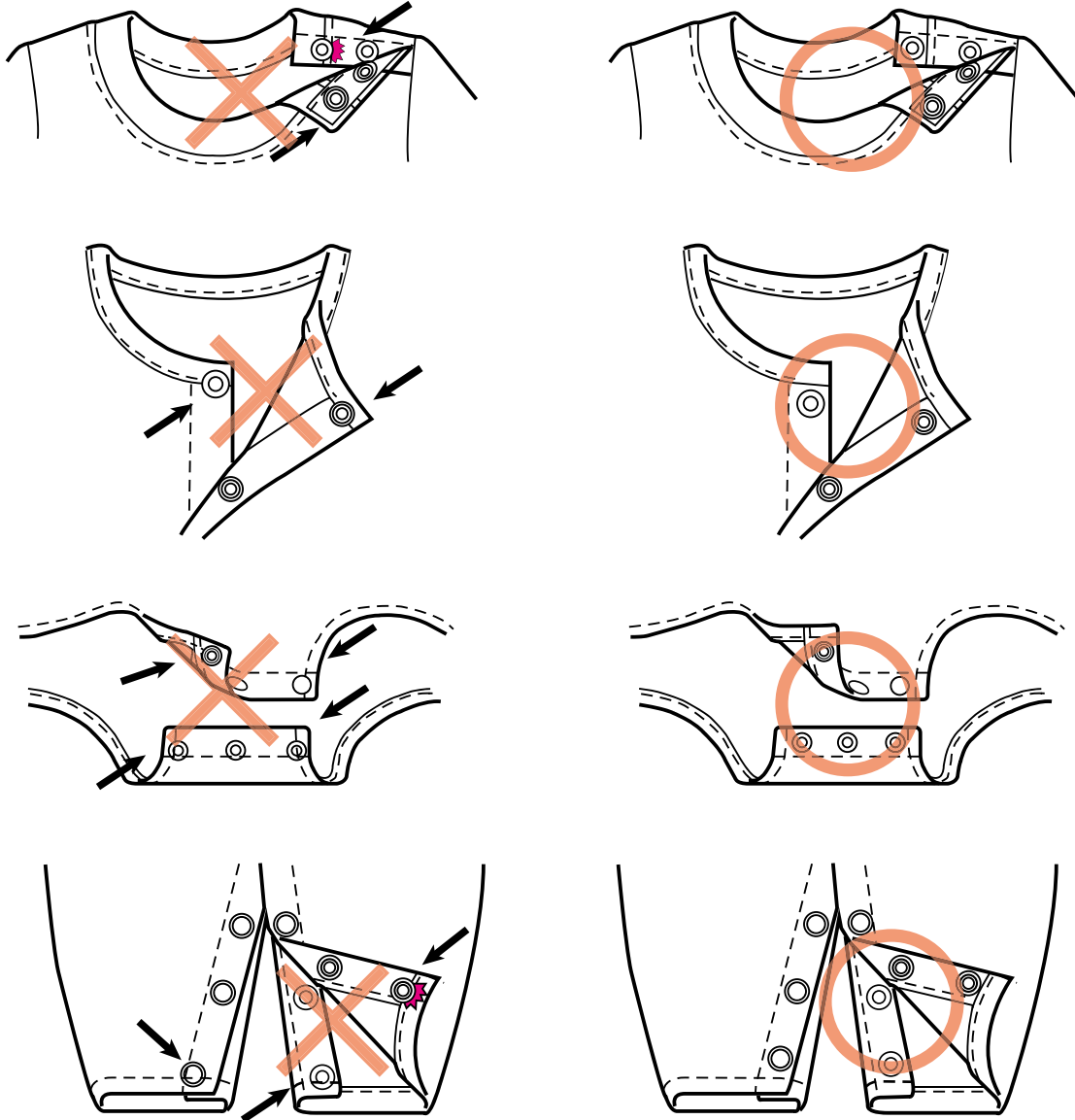

If a sewing pattern requires attachment on a particularly thick foundation, please contact your nearest YKK sales office.

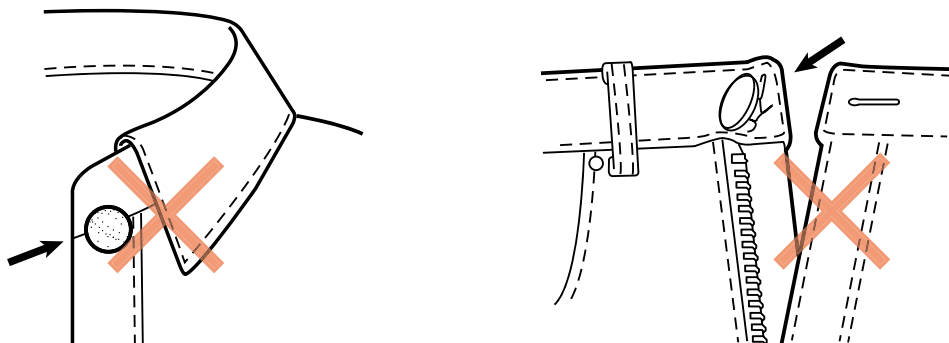

Inspection Guide

At the beginning of the working day, be sure to check that there are none of the conditions marked with a X below. Snapping and unsnapping actions should not be too weak or too stiff.

Make sure the item is not turning and there is no damage or deformation.

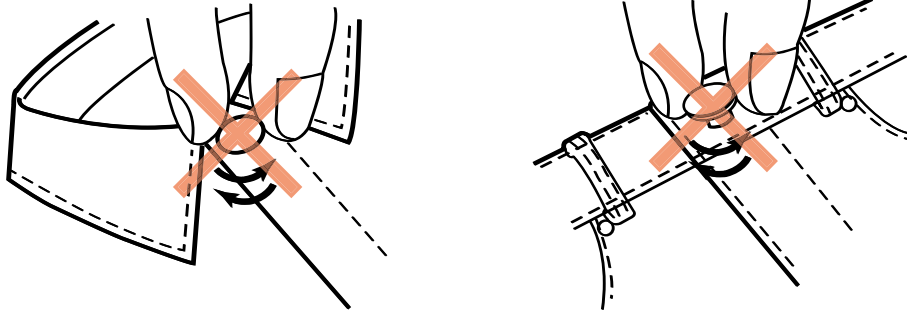

The item may turn around if the fabric is too thin. Packing is required in this case.

Make sure the item does not come off easily. Try to pluck it off with your fingertip or nail. Make checking for this your routine at the beginning of the working day.

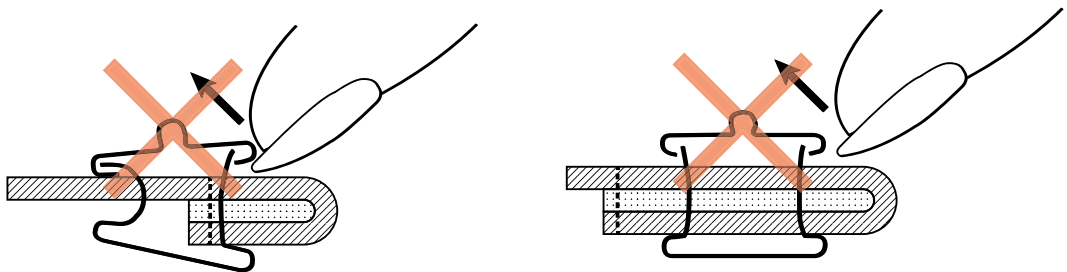

Make sure the fabric around the item is not torn. The item should not be attached on uneven thickness or over the stitching.

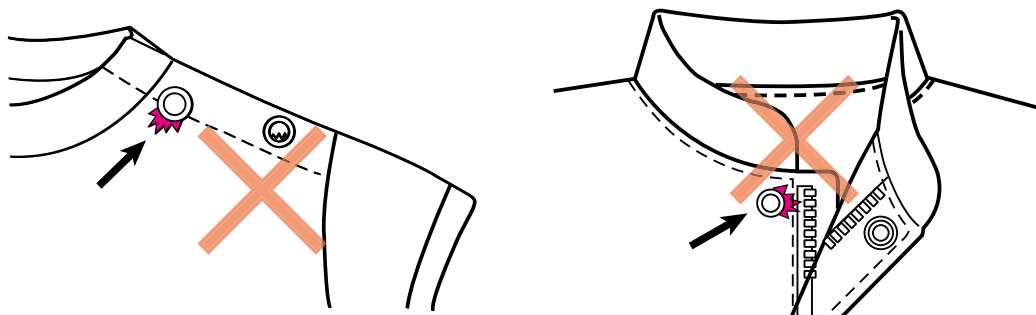

Attach inside the stitch line. Items over zipper tapes may cause fabric to tear.

Inspection Guide

During the attachment and inspection processes, be sure to check that there are none of the conditions marked with a X below, which may cause the fabric to tear or the items to come off.

Tack Button

Make sure there is no gap between the fabric and the Tack Button, and confirm they are firmly attached.

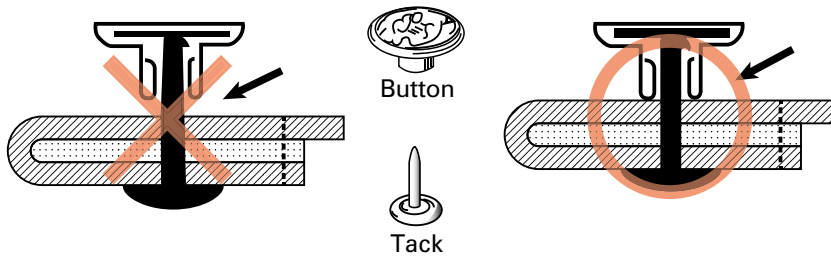

Rivet & Burr

Make sure there is no gap between the fabric and the Rivet & Burr, and confirm they are firmly attached.

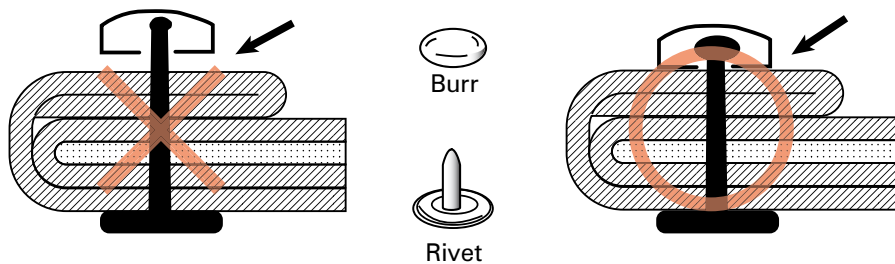

Eyelet Washer

Make sure the tip of the Eyelet is properly curled, and confirm that the fabric does not slide off the attached Eyelet with a little pulling force.

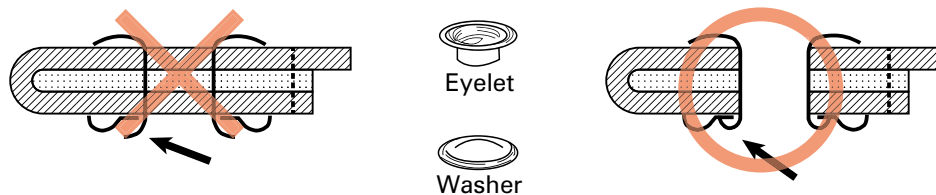

Use some packing if the fabric is too thin.

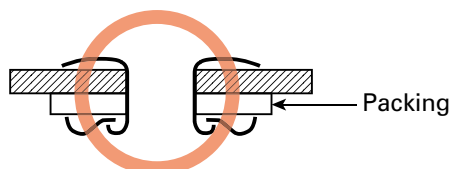

Inspection Guide

Snap

Make sure the tip of the Cap is properly curled.

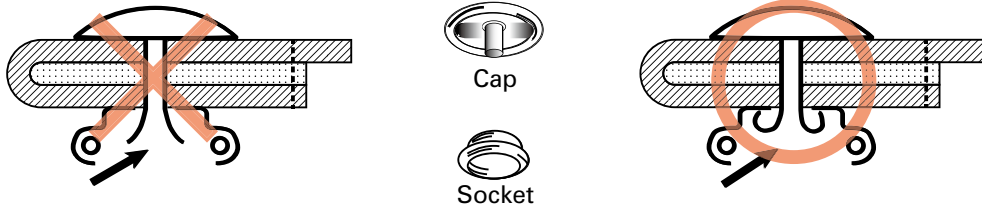

Make sure the Stud and Post are firmly attached.

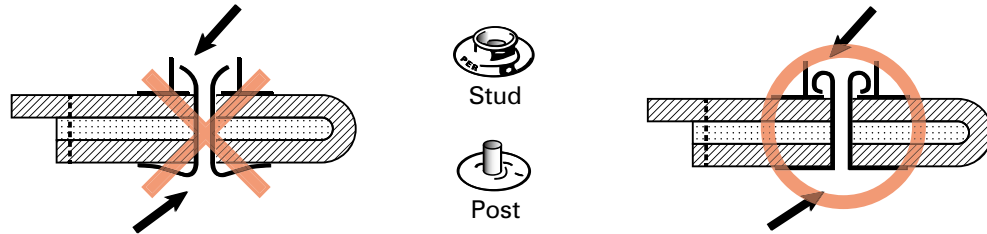

SNAPET®

Make sure there is no gap between the fabric and SNAPET®, and confirm the SNAPET® is firmly attached.

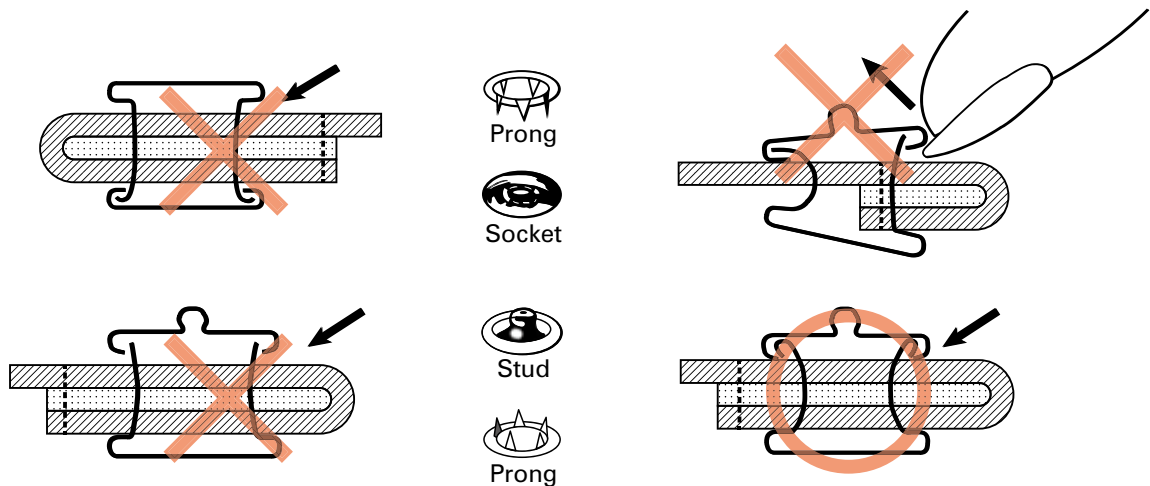

Make sure the bottom of the SNAPET® Post is flat.

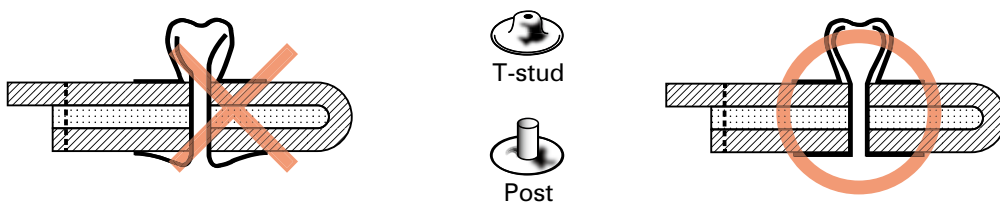

Inspection Guide

Before packing your garments, make sure to check that there are none of the conditions marked with a X below.

Tack Button

Make sure the fabric around the Tack and Button is not torn.

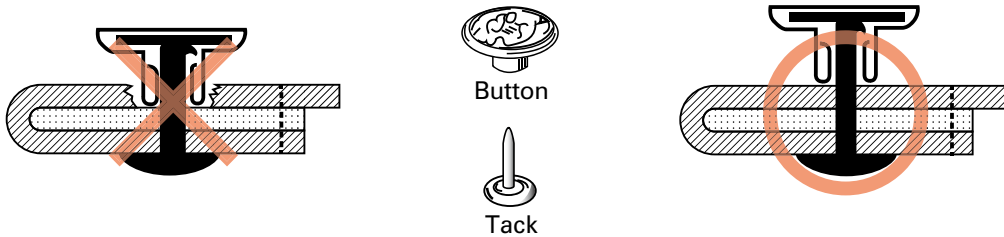

Snap

Make sure the fabric around the Stud and Post is not torn.

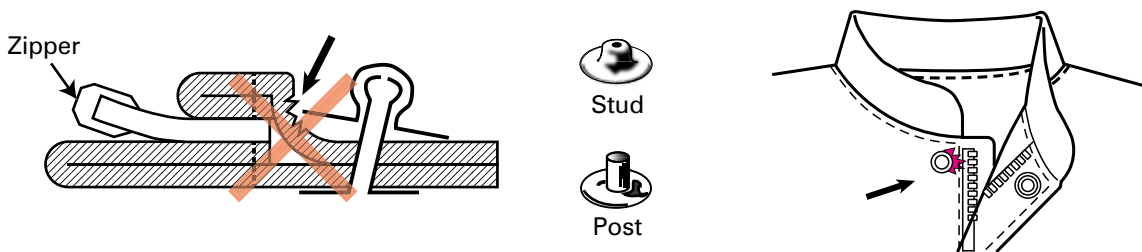

SNAPET®

Make sure the SNAPET® Prong is not protruding.

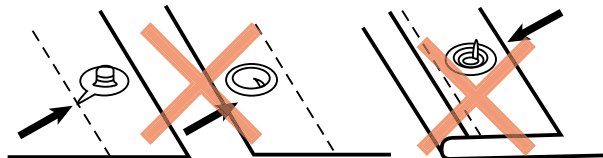

Check the back placket, and make sure that the Prong is not protruding there as well.

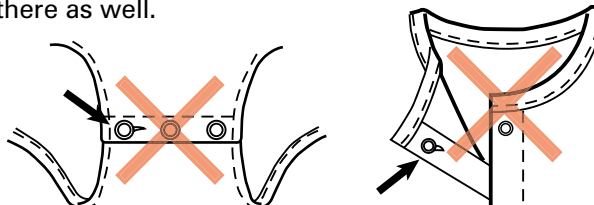

Eyelet Washer

Make sure that the attachment pressure is not too strong and the fabric is not torn.



Key Inspection Points

YKK Snap Fastener and Button items are made of various materials, and they may be vulnerable under certain conditions. See the following notes and prevent unnecessary problems.

Finishing

1. Ironing:

Do not iron directly on to the items. Direct ironing may cause scratches and deformation on metallic items and breakage or distortion on plastic items. If ironing is essential, place a fabric over the items and keep the appropriate temperature and avoid direct ironing.

2. High-Impact Press:

Problems such as deformation, breakage, stiff or weak snapping-unsnapping actions may occur, if the pressure is too strong.

3. High-Temperature Drying:

Plastic items, under high temperature, are less resistant to deformation, discoloration, and scratches.

Dyeing and Washing

■ Heavy chemicals used in the processing of fabrics or garments tend to affect metallic items, especially when they are not sufficiently rinsed and dried.

1. Sulfur Dyestuffs:

Sulfur dye process can result in corrosion on protective lacquer on all finishes, resulting in possible corrosion of the trim and/or staining on the garment fabric. As such, YKK recommends wash testing under bulk conditions before production.

2. Reactive Dyestuffs:

Reactive dye process can result in corrosion on all metal trims, especially under extreme or prolonged humid conditions. Resulting in possible corrosion of the trim and/or staining on the garment fabric. As such, YKK recommends wash testing under bulk conditions before production.

3. Dyeing On Garment:

YKK recommends all metal trims to be attached after the fabric dyeing process. This is to avoid any possible chemical reactions that can result in corrosion of the metal trim and/or staining on the garment fabric. If required to be attached before the dyeing process, please test under bulk conditions before production for variation approval.

4. Bleaching:

YKK recommends all metal trims to be attached after the bleach wash process as it can cause chemical reactions resulting in fabric failure, corrosion, and/or discolorations. If required to be attached before the bleach wash process, please test under bulk conditions before production for variation approval.

5. Stone Wash:

YKK recommends all metal trims to be attached after the stone wash process as it can cause abrasion and corrosion on metal trims. If required to be attached before the stone wash process, please test under bulk conditions before production for variation approval.

※Prior dyeing and washing tests are necessary to avoid any problems.

※Apply regular checks during bulk production.





Attachment on Leather Products

■ Leather goes through strong chemical treatments in its tanning process, and residues of such chemicals tend to discolor metallic items. Please consult your nearest YKK sales office for leather application.

Metal Ball Chain

YKK's ball chains are made of stainless steel material.

Because of their functional and fashionable characteristics, ball chains are used in a variety of fields.

Stainless (St.) BALL CHAIN					
Ball Size	Material		Ball Size	Material	
2.3	St.		4.0	St.	
3.2	St.		4.5	St.	

Attachment

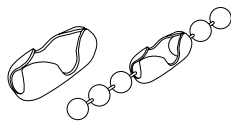

Connector (CNA)

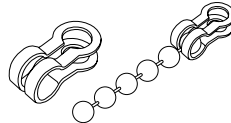

Coupling B (CPB)

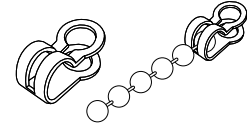

Coupling C (CPC)



※Depending on the size, the attachments can be shared.

※Please use items that have appropriate properties for your desired uses.





Plastic Ball Chain

Plastic balls are attached to a nylon or polyester string, which is flexible, bends freely, and soft to the touch. Available colors are standard and bright fluorescent. A two-tone color ball is also available with string and balls of different colors.

Standard Color Variations

055		80C1	
501		80C2	
504		80C3	
519		80C4	
540		80C5	
560			
568			
580			

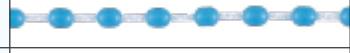
Glow in the dark Color-Variations

M1 White	
M2 Green	
M3 Yellow	
M4 Blue	
M5 Pink	

Attachment



Connector (CNA)

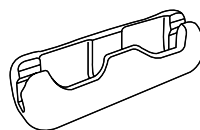

Reinforced Connector (CNA2)



Coupling (CP)

Size Variations

Unit: mm

	D (outer diameter)	L (length)	P (pitch)
35BR	3.5	4.5	8.8
48BR	4.8	6.2	12.0
58BR	5.8	7.0	13.5

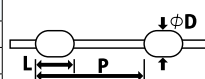



Material

	Cord Material	Plastic Ball
35BR	Polyester	Polyacetal
48BR	Polyester	
58BR	Nylon	





JOYLON® (Rail Seal Fastener)

We offer various JOYLON® items for usage ranging from stationery and fancy goods, to industrial materials.
JOYLON® Products: Six types of PVC products/Four types of Olefin products
 Seven standard colors/Transparent colors and DTM are also available.

Olefin Products

- | | | |
|-------|---|--|
| 2EVVN |  | <ul style="list-style-type: none"> ● Can be high-frequency/ultrasonic processed or heat sealed on EVA film. ● No slider necessary-open and close with fingers. ● EVA-based. |
| 3EVV3 |  | <ul style="list-style-type: none"> ● Can be high-frequency/ultrasonic processed or heat sealed on EVA film. ● EVA-based. |
| 3PPNL |  | <ul style="list-style-type: none"> ● Can be ultrasonic processed or heat sealed on PP film. ● PP-based. |

PVC Products

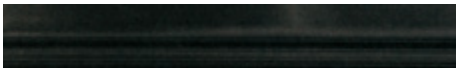
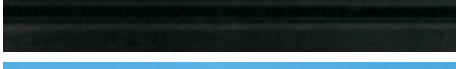
- | | | |
|--------|---|--|
| 2PVVN |  | <ul style="list-style-type: none"> ● No slider necessary-open and close with fingers. |
| 2PVV |  | <ul style="list-style-type: none"> ● Small size. ● The rail has no directions, two sliders can be passed from both sides. |
| 3PVV |  | <ul style="list-style-type: none"> ● Standard type. ● The rail has no directions, two sliders can be passed from both sides. |
| 3PVH |  | <ul style="list-style-type: none"> ● Horizontal type for opening and closing flat faces. |
| 5PVH |  | <ul style="list-style-type: none"> ● Flat type in large size. |
| 23PVVS |  | <ul style="list-style-type: none"> ● Splash-proof. ● Made by combining 3PVV and 3PVVN. |



Color Variations

Standard Colors



Transparent Colors



Care Instructions

Care Instructions for JOYLON® Applications

- Avoid use on garments. JOYLON® is easily affected by twisting and folding which occur during washing and dry cleaning processes. It also has a weak tolerance toward chemicals.
- Avoid use for water-proof purposes. JOYLON® does not have water repellent functions.
- We do not guarantee the compatibility of JOYLON® with final products. Be sure to select the product compatible with your purpose of use and conduct tests for required quality. If you have any inquiries, please do not hesitate to contact us.

Care Instructions for JOYLON® Attachment

- Avoid use on curved application.
- Avoid use on excessively long part or where certain strength is required. It may interfere with closing of the seal.
- Conduct the adhesion test of the film in advance.

Care Instructions for JOYLON® Usage

- Avoid use in extremely cold (especially those made of PVC) and hot conditions.
- Keep closed after attaching. If kept open, the rail part may turn wavy.
- Avoid storing under direct sunlight for a long period of time to avoid the change of colors.
- Regardless of the production stage (i.e. chain roll, after processing), the product may get affected by factors such as temperature, humidity, and sunlight as shown

below:

PVC products: bleeding of plasticizer

Olefin products: Occurrence of lubricant powder

- There is a possibility of slight expansion and contraction by the change of temperature.

Care Instructions for PVC (vinyl chloride) Usage

- If stored in a cold condition, keep it at normal temperatures before use. If the product is used soon after, it may result in damage.
- There is a possibility that the temperature inside the product is still cold even after keeping it at normal temperatures. Make sure to let it stay for enough time.
- PVC products have a tendency of stiffening under cold temperatures. Even a light impact may cause them to break.
- Phthalate ester in PVC conforms to the standards of Oeko-tex® Class I and CPSIA.

Care Instructions for 2EVVN/2EVTN/2PVVN Usage

- 2EVVN, 2EVTN, and 2PVVN are easy to open from the outer side but hard to open from the inner side.
- The "Round edge" is to help you check the correct direction of the chain. When attaching to the bag, make sure the "Round edge" is pointed to the outer side of the bag.

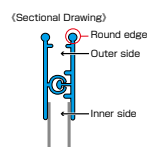

Principle of Cosmolon®

Engagement of Hook and Loop

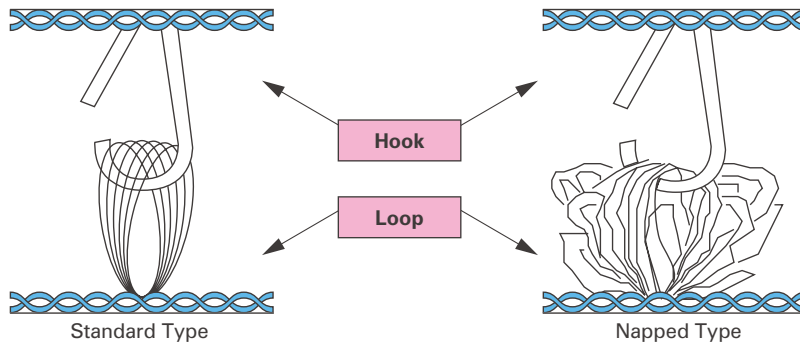

Cosmolon® (Hook and Loop Fastener)

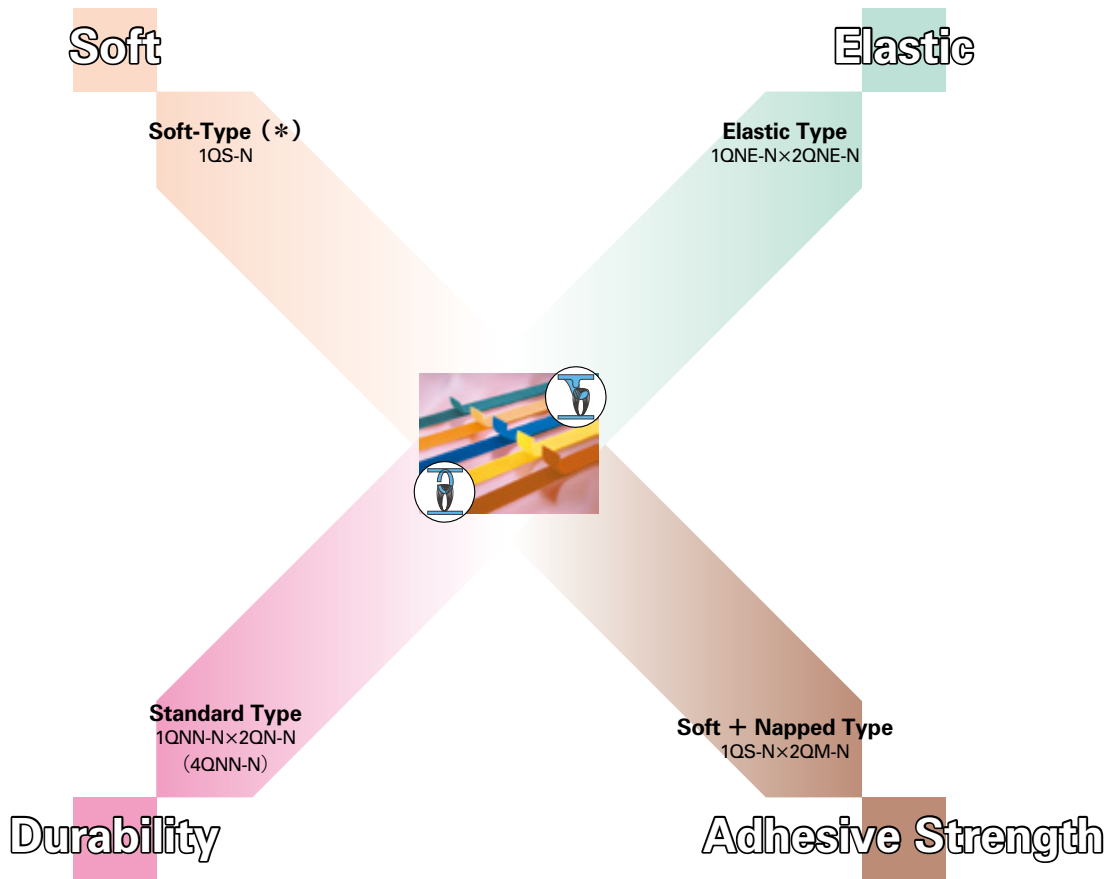

※Please consult with YKK sales representatives about the loop used with 1QS-N.

Hook

●Standard Hooked Type



Excellent in durability

●Injection or Extruded Type

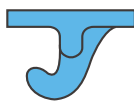

Injection molded in various shapes to suite use

Loop

●Standard Type

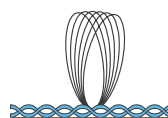

Excellent in durability

●Napped Type

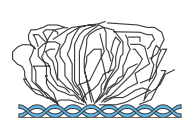

Excellent in engaging strength

Cosmolon®

Cosmolon® Types and Uses

		Kind	Material	Features	Main Uses		
Cosmolon® (Hook and Loop Fastener)	Hook Tape (A)	Woven	STANDARD type 1QNN-N	<ul style="list-style-type: none"> ■ Fish hook-shaped pile for reliable engagement. ■ Uses a thick monofilament hook. ■ Normal type 	<ul style="list-style-type: none"> ● Apparel ● Bags, pouches, shoes, gloves, belts, tool cases, and sporting, leisure and amusement goods. 		
			SOFT type 1QS-N	Nylon	<ul style="list-style-type: none"> ■ Fish hook-shaped pile for reliable engagement. ■ High-density pile with thin monofilament hook, softer to the touch, yet strong. 	<ul style="list-style-type: none"> ● Handicrafts, interior decoration items ● Trims and seats of automobiles, trains, and airplanes (fire-resistant type) ● Medical appliances such as corsets and tonometers 	
		Polyester		<ul style="list-style-type: none"> ■ Compared to nylon tapes, superior both in water resistance and UV-resistance. 	<ul style="list-style-type: none"> ● Medical appliances such as corsets and tonometers 		
		Injection	POWERHOOK® Button 1QJ * *.*	Nylon Polyester	<ul style="list-style-type: none"> ■ Injection molded type hook in various shapes. ■ The injection molded hook provides stronger shear and peel strength than woven hooks. 	<ul style="list-style-type: none"> ● Interior decoration items such as curtains ● Automobile-related items 	
	Continuous Injection	POWERHOOK® 1QE * *.*	PP PE POM	<ul style="list-style-type: none"> ■ Continuous injection molded type hook. ■ Continuous injection molded type hook provides stronger shear and peel strength than woven hooks. 	<ul style="list-style-type: none"> ● Daily necessities such as cleaning tools ● Belts ● Industrial materials 		
	Loop Tape (B)	Woven	STANDARD type	2QN-N	Nylon	<ul style="list-style-type: none"> ■ Mates with all hook tapes. ■ Consists of bundled loop pile. ■ Provides higher shear strength. 	<ul style="list-style-type: none"> ● Apparel ● Bags, pouches, shoes, gloves, belts, tool cases, and sporting, leisure and amusement goods.
				2QN-P	Polyester	<ul style="list-style-type: none"> ■ Compared to nylon tapes, superior both in water resistance and UV-resistance. 	<ul style="list-style-type: none"> ● Handicrafts, interior decoration items ● Trims and seats of automobiles, trains, and airplanes (fire-resistant type) ● Medical appliances such as corsets and tonometers
		NAPPED type 2QM-N	Nylon	<ul style="list-style-type: none"> ■ Mates with all hook tapes. ■ Consists of napped loop pile. ■ Stronger peel strength than standard type loop. 	<ul style="list-style-type: none"> ● Medical appliances such as corsets and tonometers 		
	Mixed (AB)	Woven	MIXED type 4QNN-N	Nylon	<ul style="list-style-type: none"> ■ Hook and loop are mixed on the same tape. ■ No distinction between the hook tape and the loop tape. 	<ul style="list-style-type: none"> ● Apparel (ski wear, etc.) ● Gloves, belts ● Beddings, interior decoration items 	

Special Varieties of Cosmolon®

WE Type	Cosmolon® fasteners used in high-frequency welding onto soft PVC sheet.
WE-T Type	Cosmolon® fasteners used in high-frequency welding onto fabrics, textiles, etc. for a temporary bond..
AD Type	Cosmolon® fasteners with a double-sided adhesive tape on its reverse side for a temporary bond.
ADN Type	Cosmolon® fasteners with an acrylic-based adhesive on its reverse side for a temporary bond. ※1
ADS Type	Cosmolon® fasteners with a rubber-based adhesive optimized for low energy surface. General purpose. ※2
HMPP Type	Cosmolon® fasteners with a stronger rubber-based adhesive optimized for low energy surface, such as PP and PE.

※1. ADN type is applicable to soft PVC, however the ADN can react with plasticizers, affecting bond strength.

※2. ADS type and HMPP is easily affected by plasticizers within soft PVC. Please refrain from using ADS type and HMPP on soft PVC substrates.

FP type	Fire retardant hook & loop fastener which satisfies the U.S. Federal Automobile Safety Standards FMVSS-302.
FA type	Fire retardant hook & loop fastener which satisfies the U.S. Federal Aviation Specifications, FAA-23-853 (b)

■ Cosmolon® Sizes and Shapes

Widths : 16, 20, 25, 50 and 100mm

Put-up : 25m and 50m on spool

Cosmolon® Strength Test

● Shear Strength Test

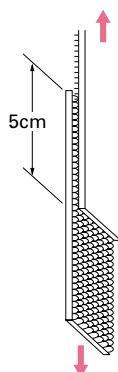

● Peel Strength Test

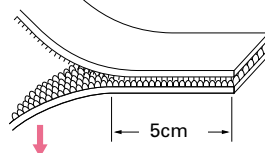
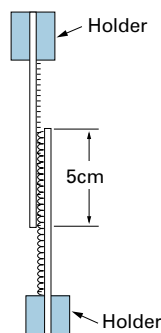

(Under conditions of 20°C×65%RH)
fastened length of 50mm

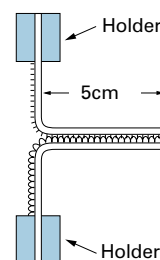

※Tests based on JIS-L-3416-2000

Information concerning safe operation

Carefully read the following information so you can make the best and safest use of our fastening products.

YKK goes to great lengths to maintain the quality and safety of our products while making sure they are comfortable for our customers to use.

Our sales staff is prepared to assist you in all stages of your product development projects, from planning to setting up specifications. Feel free to consult with them at any time.

Caution

- Our plastic hardware is developed for luggage, bags, and apparel. If you use our product for any specialized use, and especially for one of the applications listed below, please contact your YKK sales representative.
 - Personal flotation devices (PFD), baby carriers (baby sling), or any other applications which are subject to particular standards;
 - stretchers, safety belts, or any applications which are for weight-bearing;
 - child seats, wheelchairs, or any applications for use to reduce movement;
 - hard hats or any applications which provide safety features.

The above list is provided by way of example and is not intended to be exhaustive. We cannot guarantee that a product is suitable for a particular application, and as such, you should always conduct your own tests.

- Once our products are attached to other items, there may be approved ways to pack, store, or ship them in order to ensure their continued high quality. For example, buckles should be correctly fastened in order to avoid deformation, breakage or detachment.
- Please contact your sales representative about the certification of Oeko-Tex standard 100 or others.

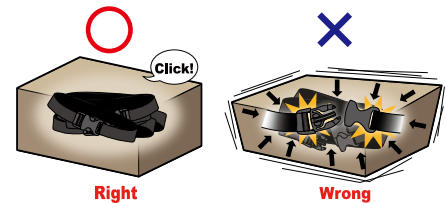

When using our products, you should

- Choose the right fastener for your application from our product line. Your YKK sales representative can help you understand the variety of our products, their sizes, strengths, and specifications.
- Select plastic hardware that is the appropriate size for the tape in your application.
- Refrain from using plastic hardware that has been exposed to or is covered in dirt of any sort. Product damage or malfunction may arise if the plastic hardware is not clean.
- Refrain from using plastic and metal parts in one unit because of the potential for product abrasion.
- Refrain from using goods left outdoors for a long time. Exposure to the sun and other elements may cause product discoloration and/or quality deterioration.
- Avoid using items that have been in contact with or near a heat source. Heat may cause product deformation and/or quality deterioration.
- Refrain from using goods that have been in direct or indirect contact with chemicals. Check for residual chemicals on all parts of plastic hardware whether applied by YKK or coming from another source.
- Refrain from using a product in a position that is subject to pressure, impact, or abrasion, or other condition where product deformation and/or damage may result.
- Only make your choice of YKK product after adequate checks have been made. The strength of YKK products depend on the materials used, its texture, the thickness of its webbing, the position of its weld line, and other factors which you will need to take into account. For further information, please contact your YKK sales representative.
- Due to certain material combination, noise from friction may be possible. If silent operation is necessary, please contact your YKK sales representative for detail.

Recommendations for using YKK Buckles

- When fastening a buckle, insert the plug straight into the intended socket until you hear a clicking sound indicating the two parts are interlocking. Next, lightly pull on both parts to confirm that they have been completely fastened.

Incomplete fastening may result in product deformation and damage to any article attached to the buckle, especially if the plug comes loose from the socket. If the two parts cannot be fastened together, check again for any foreign material. Do not try to force the plug into the socket.

- Buckles should not be used in positions where they will be put under external pressure.
- All plastic materials deteriorates over time. Buckles that have been used for a long time should be checked for damages, cracks, deformations, and abrasions before each use. If any abnormalities are found, stop using them immediately. Use in such circumstances may cause further product damage and/or malfunctions.
- Completely remove any foreign materials including dust, sand, or mud from buckles before use.
- Situations which involve the application of excessive pressure or impact to a plastic fastener, such as being stepped on, struck, or thrown, will result in lower performance.
- We will not be held responsible for damage to the buckles or unauthorized modification of buckles.

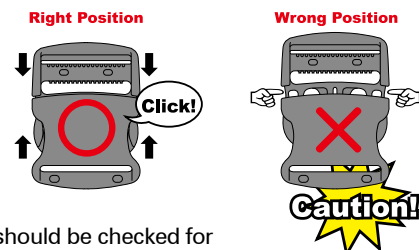

Material Properties

- All of our products are limited by the properties and qualities of the materials used.
- Some products have a weld mark (the line that forms when materials bond within its mold during production). The mark is not a defect, damage or crack. Please check the product carefully before using.

Plastic Hardware

Buckle

LB-YC



Sharpn'Loc™

LB-YCD



Sharpn'Loc™

LB-YCS



Sharpn'Loc™

LB-YCT



Sharpn'Loc™

LM-YC



Sharpn'Loc™

LB-TS



2 Way Release

LB-TSD



2 Way Release

LM-TS



2 Way Release

LB-RT



Flapped Buckle

LB-MP



UL approved

LB-EQ



Rotatable

LB-LW



Ultra-Lightweight

LB-LWD



Ultra-Lightweight

LB-LWS



Ultra-Lightweight

LM-LW



Ultra-Lightweight

LB-MV



LB-MVD



LB-MVS



LB-MVW



LM-MV



LB-HE



LB-HED



LB-LV



Lightweight

LB-LVD



Lightweight

LB-LVS



Lightweight

LM-LV



Lightweight

LB-WG



SHOCKONLOC™

LB-WGD



SHOCKONLOC™

LB-WGS



SHOCKONLOC™

LB-WG1



SHOCKONLOC™

LB-WGD1



LB-WGS1



LB-PT



HAMMERLOC™

LB-PTD



HAMMERLOC™

LB-PTS



HAMMERLOC™

LB-PTA



HAMMERLOC™

LM-PT



HAMMERLOC™

LB-PTC



HAMMERLOC™

LM-D / DB



LM-DH / DHB



LB-R



These fastening products are intended for the apparel and luggage industries, but technical assistance and support are available for users interested in other applications.

LB-RD  UL approved	LB-RP  UL approved	LB-RN 	LB-RND 	LB-X  CYBERLOC™	LB-XD  CYBERLOC™	LB-XC  Curved
LB-RH  Curved	LB-RC  Curved	LB-PC  Curved	LB-LB  Minimal	LB-LS  Minimal	LB-RS  Thin	LB-S 
LB-FR  Minimal	LB-F2 	LB-FU 	LB-Q  Rotatable	WB-S1  Suspender	LB-FW2/FW  3way	WB-H  Belt Buckle
WB-HS  Belt Buckle	WB-DA2  Belt Buckle	WB-DAH1  Belt Buckle	Cam Buckle	LA-CB 	LA-CBH  Hole	LA-CN 
I.D. Card Holder	LJ-H/HW 	Strap Adjuster	LK-YC  Sharpn'Loc™	LK-YCS  Sharpn'Loc™	LK-TS 	LK-HC 
LK-EA 	LK-WG  LOCWAVE™ Adjuster	LK-WGS  LOCWAVE™ Adjuster	LK-WL  LOCWAVE™ Adjuster	LK-LV  Lightweight Adjuster	LK-LVS  Lightweight Adjuster	LK-DH1  LOCWAVE™ Adjuster
LK-PT  HAMMERLOC™ Adjuster	LK-U 	LK-KU  UL approved	LK-E/EK 	LK-M 	LK-L  Lockable Adjuster	

These fastening products are intended for the apparel and luggage industries, but technical assistance and support are available for users interested in other applications.

LB-RD  UL approved	LB-RP  UL approved	LB-RN 	LB-RND 	LB-X  CYBERLOC™	LB-XD  CYBERLOC™	LB-XC  Curved
LB-RH  Curved	LB-RC  Curved	LB-PC  Curved	LB-LB  Minimal	LB-LS  Minimal	LB-RS  Thin	LB-S 
LB-FR  Minimal	LB-F2 	LB-FU 	LB-Q  Rotatable	WB-S1  Suspender	LB-FW2/FW  3way	WB-H  Belt Buckle
WB-HS  Belt Buckle	WB-DA2  Belt Buckle	WB-DAH1  Belt Buckle	Cam Buckle	LA-CB 	LA-CBH  Hole	LA-CN 
I.D. Card Holder	LJ-H/HW 	Strap Adjuster	LK-YC  Sharpn'Loc™	LK-YCS  Sharpn'Loc™	LK-TS 	LK-HC 
LK-EA 	LK-WG  LOCWAVE™ Adjuster	LK-WGS  LOCWAVE™ Adjuster	LK-WL  LOCWAVE™ Adjuster	LK-LV  Lightweight Adjuster	LK-LVS  Lightweight Adjuster	LK-DH1  LOCWAVE™ Adjuster
LK-PT  HAMMERLOC™ Adjuster	LK-U 	LK-KU  UL approved	LK-E/EK 	LK-M 	LK-L  Lockable Adjuster	

These fastening products are intended for the apparel and luggage industries, but technical assistance and support are available for users interested in other applications.

Plastic Hardware

Loop

LA-RH



LA-PYB



HAMMERLOC™ 3way-Loop

LT-K



LH-E



LT-TG



Tri-Bar Adjuster

LA-S



Wedge Adjuster

LH-W



LH-WJ



LA-EJ



Clip

LA-AXA / AXB



Attachable

LH-SG



LA-PS



Piping-Slider

Snap Hook

LN-SM



Smooth Rotate

LN-AS



Smooth Rotate

LN-M1S



Smooth Rotate

LN-M2S



Smooth Rotate

LN-ML



Smooth Rotate

LN-AR1



Swivel & Rotate

LN-RE



Swivel & Rotate

LF-CH



LF-HA



LN-SX



LN-KH



LN-ZR



Swivel & Rotate

LN-Z



Swivel & Rotate

D-Ring

LD-S



LD-E



LD-K



LD-R



LD-RE



LD-TW



Twist

Cord Stopper

LC05PS1



Plastic Spring

LC05PS3



Plastic Spring

LC05PS4  Plastic Spring	LC05PS6  Plastic Spring	LC05PS7  Plastic Spring	LC05PS8  Plastic Spring	LC05PS9  Plastic Spring	LC05SR  Plastic Spring	LC05KW  Plastic Spring
LC05HW  Plastic Spring	LC05RW  Plastic Spring	LC05KH  Plastic Spring	LC05SL  Plastic Spring	LC05SC  Plastic Spring	LC05SB  Plastic Spring	LC05WC  Plastic Spring
LC05WF  Plastic Spring	LC05MS1  Metal Spring	LC05MS2  Metal Spring	LC05MS3  Metal Spring	LC03MS5  Metal Spring	LC03MW1  Metal Spring	LC03MW2  Metal Spring
LC03MW3  Metal Spring	LC03MW4  Metal Spring	LC03MW5  Metal Spring	LC03PE  Metal Spring	Cord End Ring 	LR05E  Metal Spring	LR05T  Metal Spring
LR05F  Cord Holder	LC05UG  Sewable	LC02US  Sewable	LC10US  Sewable	LC02UC  Sewable	LC02UH2  Sewable	
LC05EL  Sewable	Zipper Cover 	WZ-CO  ZIPCAP™ Outer-Cap	WZ-SI / WZ05NI  ZIPCAP™ Inner-Cap	LZ05DLW  Key Lock	Cord End 	LE03NK  Sewable
LE05WA1  Sewable	LE03SV  Sewable	LE03WV  Sewable	LE03SN  Sewable	LE03WN  Sewable	LE03CMT  Sewable	LE01STT  Sewable

These fastening products are intended for the apparel and luggage industries, but technical assistance and support are available for users interested in other applications.

Plastic Hardware

LE07CP



LE03PC



LE05CE



LE03PB



Zipper Pull

LE02PA



IJ01SC



Belt Adjuster

5BS AABL



3BR NR06



3BR NR08



Clip

IC20RY



Cord Insert Puller

CP002A



CP004A



Tape End

1QiBD-E



POWERHOOK™ Button

WE-DA1



LE-B



Sewable

LE-PW



POWERHOOK™ Tapeend

YKK
Little Parts. Big Difference.

Fastening Products Group



We're on mission to protect our brand and your brand.

Counterfeiters, we won't let your dishonesty slide.



Brand Protection Partnership

YKK Worldwide Network as of Jul 2019

Country	Branch	Company	TEL	FAX
1. North, Central America				
USA	Chicago (GMG)	YKK (U.S.A.) INC.	1-847-657-9295	847-657-9356
USA	Dallas (Central Region)	YKK (U.S.A.) INC.	1-972-943-7770	1-972-943-5938
USA	Detroit (TFM)	YKK (U.S.A.) INC.	1-248-468-3500	1-248-468-3503
USA	HQ, Atlanta Branch covering East Region, FTC	YKK (U.S.A.) INC.	1-770-427-5521	1-770-421-3624
USA	New York (GMG)	YKK (U.S.A.) INC.	1-212-768-9776	1-212-768-9775
USA	Lyndhurst (Northeast Region)	YKK (U.S.A.) INC.	1-201-935-4200	1-201-964-0123
USA	San Francisco (GMG)	YKK (U.S.A.) INC.	1-650-581-5254	1-650-343-3317
USA	Seattle (Northwest Washington and Oregon and GMG)	YKK (U.S.A.) INC.	1-425-277-2503	1-425-277-2579
CANADA	Toronto	YKK CANADA INC.	1-905-738-7941	1-905-738-7948
CANADA	Winnipeg	YKK CANADA INC.	1-204-633-9179	1-204-633-6179
MEXICO	Mexico City	YKK MEXICANA, S.A. DE C.V.	52-55-5803-0690	52-55-5803-0699
MEXICO	Torreon	YKK MEXICANA, S.A. DE C.V.	52-871-707-0707	52-871-707-0707
GUATEMALA	Guatemala	YKK EL SALVADOR S.A. DE C.V. SUCURSAL EXTRANJERA, GUATEMALA	502-6644-0644	502-6644-0645
HONDURAS	San Pedro Sula (Headquarters)	YKK HONDURAS, S.A.	504-2553-3164	504-2553-1728
NICARAGUA	Nicaragua	YKK EL SALVADOR S.A. DE C.V. SUCURSAL EXTRANJERA, NICARAGUA	505-8986-1700	505-8986-1711
COLOMBIA	Medellin (Headquarters)	YKK COLOMBIA S.A.S.	574-322-9394	574-360-0070
2. South America				
BRAZIL	Sao Paulo	YKK DO BRASIL LTDA	55-11-3066-1111	55-3058-4755
ARGENTINA	Buenos Aires	YKK ARGENTINA S.A.	54-11-4554-3333	54-11-4553-5095
3. EMEA (Europe, Middle East, Africa)				
UNITED KINGDOM	London	YKK EUROPE LTD.	44-20-7448-1358	-
RUSSIAN FEDERATION	Moscow	OOO YKK	7-495-325-3025	7-495-231-2810
NORWAY	Oslo	YKK (U.K.) LTD. YKK NORGE FILIAL AV	47-6685-5850	47-6685-5860
SWEDEN	Boras	YKK (U.K.) LTD. FILIAL SVERIGE	46-33-418-180	46-33-416-550
FINLAND	Vantaa	YKK (U.K.) LTD. SIVULIIKE SUOMESSA	358-9-759-7860	358-9-759-78650
DENMARK	Ikast	YKK DANMARK A/S	45-97-155-388	45-97-155-449
LITHUANIA	Vilnius	YKK POLAND SP. Z O.O.	370-5-2133-227	370-5-2336132
BELARUS	Belarus Representative office	OOO YKK	375-17-350-55-57	375-17-350-55-57
IRELAND	Dublin	YKK (U.K.) LTD.	353-1-403-5959	353-1-466-0070
GERMANY	Mainhausen	YKK DEUTSCHLAND GMBH	49-6182-805-1570	49-6182-805-1570
POLAND	Rzgow shop	YKK POLAND SP.Z O.O.	48-42221-2068	-
KAZACHSTAN	Almaty	YKK TURKEY, KAZAKHSTAN REP.OFFICE	7-727-225-05-44	7727-225-05-89
UKRAINE	Kiev	YKK POLAND SP. Z O.O.	380-44-461-98-67	380-44-461-98-69
BELGIUM	Belgium	YKK FRANCE SARL	32-9385-57-51	32-9-385-65-20
FRANCE	Paris	YKK FRANCE SARL	33-140-89-6200	33-140-89-6222
CZECH REPUBLIC		YKK CZECH SPOL S.R.O	420-5-31-01-54-00	420-5-31-01-54-15
AUSTRIA	Marz	YKK EUROPE LTD.	43-2626-624-05 43-2626-624-55	43-2626-624-55-60
ROMANIA	Bucharest	YKK ROMANIA SRL	40-214-087-160	40-214-087-199
BULGARIA	Sofia Representative Office	YKK TURKEY	359-2-489-9433-34	359-2-489-9435
ITALY	Milano	YKK ITALIA SPA	39-023-394-051	39-02-3533008
SPAIN	Barcelona	YKK ESPANA SA	34-93-447-9700	34-93-447-9731

Country	Branch	Company	TEL	FAX
PORTUGAL	Porto	YKK PORTUGAL-ACESSORIOSPARA VESTUARIO LTA.	351-22-961-9820	351-22-960-0023
GREECE	Thessaloniki	YKK HELLAS A.E.B.E.	30-2310-327830 30-2310-328270	30-2310-317388
TURKEY	Istanbul	YKK METAL VE PLASTIK URUNLERI SANAYI VE TICARET A.S.	90-212-314-7900	90-212-314-8040
LEBANON	Beirut	YKK MIDDLE EAST SAL	961-1586-687	961-1-586354
JORDAN	Amman	YKK MIDDLE EAST SAL, JORDAN OFFICE	962-6582-7929	962-6-5827930
UNITED ARAB EMIRATES	Dubai	YKK MIDDLE EAST SAL, DUBAI REPRESENTATIVE OFFICE	971-4-3362-840	971-4-3362-841
MOROCCO		YKK MAROC S.A.R.L	212-5-22-34-29-15	212-5-22-35-25-70
EGYPT	Alexandria Home office	YKK EGYPT S.A.E. PRIVATE FREE ZONE	20-127-3446-222	-
KENYA	Mombasa	YKK KENYA EPZ LIMITED	254-20-2054188	254-20-2051150
MAURITIUS	Mauritius	YKK SOUTHERN AFRICA (PTY) LTD.	230-467-4431	230-466-9508
SOUTH AFRICA	Johannesburg	YKK SOUTHERN AFRICA (PTY) LTD.	27-11-781-4240	27-11-781-4250

4. China

CHINA	Shanghai (Office)	SHANGHAI YKK ZIPPER CO.,LTD.	86-21-2509-9988	86-21-5405-0830
CHINA	Beijing	DALIAN YKK ZIPPER CO.,LTD.	86-10-5979-8626	86-10-85860473
CHINA	Dalian Branch	DALIAN YKK ZIPPER CO.,LTD.	86-411-8250-9088	86-411-8250-9077
CHINA	Qingdao	DALIAN YKK ZIPPER CO.,LTD.	86-532-8163-7090	86-532-8501-6500
CHINA	Guangzhou	YKK ZIPPER (SHENZHEN) CO., LTD.	86-20-3847-7968	86-20-3839-9832
CHINA	Shenzhen (Futian Office)	YKK ZIPPER (SHENZHEN) CO., LTD.	86-755-8287-2288	86-755-8287-2201
CHINA	Xiamen	YKK ZIPPER (SHENZHEN) CO., LTD.	86-592-268-6200	86-592-268-6201
CHINA	Shang Hai (Hong Qiao)	YKK FASTENING PRODUCTS SALES (SHANGHAI) CO., LTD.	86-21-6236-9292	86-21-6236-8520
HONG KONG	Kowloon	YKK HONG KONG LTD.	852-2378-8300	852-2375-6088

5. Asia

KOREA (SOUTH)	Seoul	YKK KOREA CO.,LTD.	82-2-3705-7900	82-2-3705-7991
PAKISTAN	Lahore Sales Office	YKK PAKISTAN (PVT) LIMITED	92-42-3579- 2020/2021/2022	92-42-3578-1671
INDIA	Gurgaon	YKK INDIA PVT.LTD.	91-12-4392-4800	91-12-4392-4898/9
NEPAL	Kathmandu Liaison Office	YKK INDIA PVT.LTD.	98-01-110145 98-01-5111146	-
MYANMAR	Yangon	YKK (THAILAND) CO., LTD.	95-9-263671850	-
BANGLADESH	Dhaka (office)	YKK BANGLADESH PTE LTD.	880-2-9842227 880-2-58814502	880-2-9843716
TAIWAN	Taipei	YKK TAIWAN CO.,LTD.	886-2-2511-5157 886-2-2511-5156 (AP Division)	886-2-2563-5572
VIETNAM	Ho Chi Minh	YKK VIETNAM CO., LTD.	84-28-382-33793	84-28-382-33795
THAILAND	Bangkok	YKK (THAILAND) CO., LTD.	66-2-718-0590	66-2-718-0591
CAMBODIA	Phnom Penh	(YKK VIETNAM CO., LTD. PHNOM PENH REPRESENTATIVE OFFICE)	855-23-723-637	855-23-430-685
PHILIPPINES	Manila	YKK PHILIPPINES, INC.	63-2-781-1658	63-2-807-8660
SRI LANKA	Colombo	YKK LANKA (PRIVATE) LTD.	94-11-5579200	94-11-2574614
MALAYSIA	Johor Bahru	YKK (MALAYSIA) SDN BHD	60-7-237-4389	60-7-237-4890
INDONESIA	Jakarta	PT. YKK ZIPPER INDONESIA	62-21-3193 1708	62-21-310-6751
INDONESIA	Jakarta	PT. YKK ZIPCO INDONESIA	62-21-3193-1708	62-21-310-6751
AUSTRALIA	Sydney Sales Office & Plant	YKK OCEANIA LTD AUSTRALIA BRANCH	61-2-9577-1955	61-2-9577-1999
FIJI	Suva	YKK OCEANIA LTD FIJI BRANCH	679-3385-699	679-3384-909
NEW ZEALAND	Wellington Home Office	YKK OCEANIA LTD.	64-04-383-4058 / 64-21-439-017	64-09-269-0287

Any product names that are marked with the ® symbol are registered trademarks of YKK Corporation.



YKK CORPORATION
1, Kanda Izumi-cho, Chiyoda-ku, Tokyo 101-8642, Japan
Phone: (03) 3864-2091 Facsimile: (03) 3864-2092



 **YKK CORPORATION**
<http://www.ykkfastening.com>